

电动尾门	CR-V
------	------

安装位置图

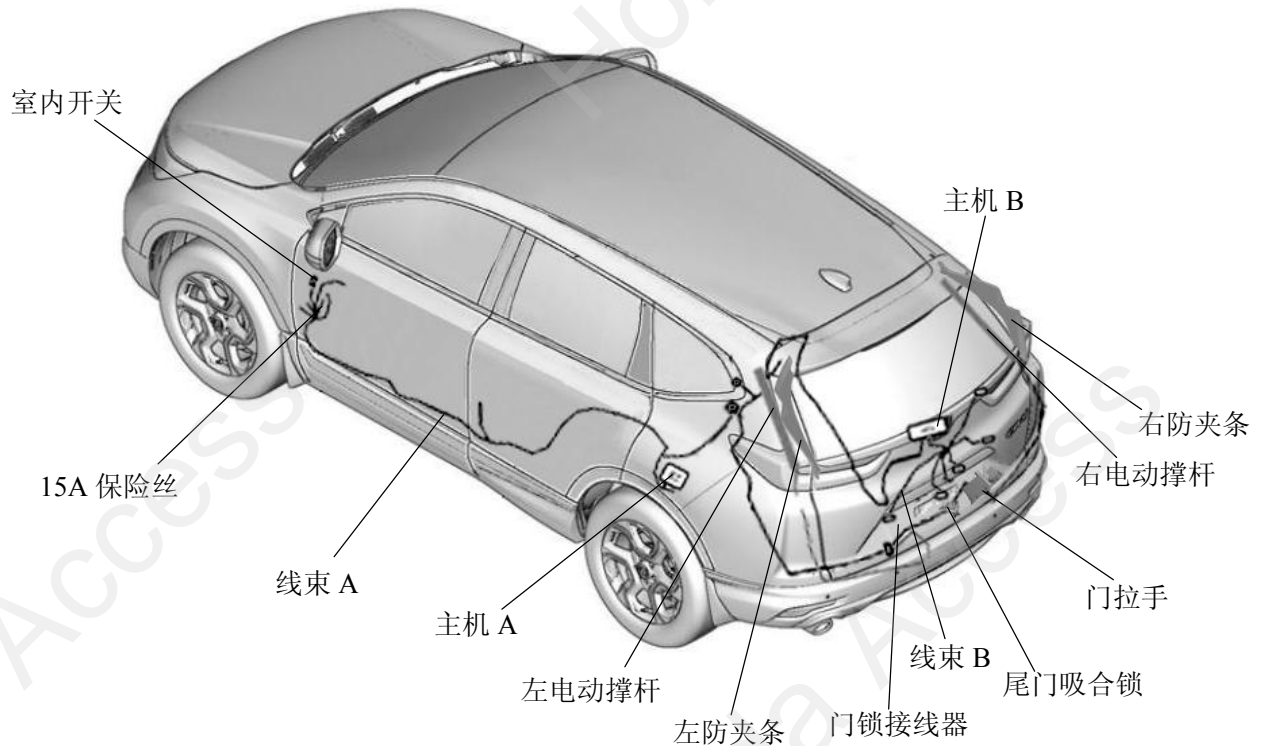

为确保安装的安全（务必仔细阅读）

警告标志的说明

- 本书中使用以下标志来标明有可能造成操作人员或其他人受伤害的操作，以及有关安装的建议。



不遵从该指示，将导致死亡或者其他严重伤害



不遵从该指示，有可能导致死亡或者其他严重伤害



不遵从该指示，有可能导致受伤



防止导致故障、破损的建议



禁止事项

关于图标

- 使用下列图标来标明安装的位置和操作人员的视线角度。

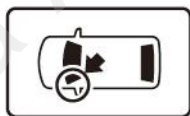

车身对应位置



仪表板对应位置

- 使用下列图标来标明操作中必须遵守的事项。



佩戴防护眼镜



双人作业



除去毛刺



保管好零件（还给客户）



使用规定扭力上紧螺丝



使用脱脂洗洁剂清洗



带皮手套



放置于纸皮箱或毛毯上



涂抹修补漆后充分干燥



用力压紧粘贴面



垂直安装面操作

线束操作注意事项

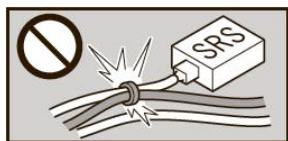

请不要把用品线束与 SRS 线束扣夹在一起。



接线器、端子类的接线请用力插入，直到锁紧为止。



拆卸接线器、端子之类的接线时，请不要用力拉拽线束。



从支撑杆拆下的接线器必须接回原位。

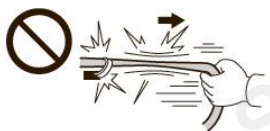

请不要用力拉拽线束。



用品线束要扣在指定场所，不能松垮。



线束不要夹压在零件中间。

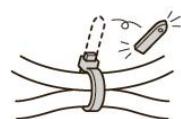

切断线束胶带的剩余部分。

一般的注意事项

- 请按照安装说明书的记载事项及服务手册中的相关事项和信息进行操作。特别要注意安全方面。
- 不要划伤、损坏车辆及相关零件。
- 特别要注意夹扣和爪扣的操作。
- 拆卸前应考虑如何装回原样，先确认安装时的状态后才开始拆卸零件。

安装电装零件的注意事项

- 进行安装操作时必须请先断开车辆电瓶的负极端子。

关于本用品的注意事项

- 螺栓、螺丝等必须使用本说明书的指定零件。否则，随意使用类似的零件有可能导致故障发生。
- 安装以及粘贴操作请不要在太阳直射的地方，多尘的地方进行。
- 粘贴时必须保证粘贴面的温度在 15~40°C。
- 特别是低温时会导致双面胶带粘性降低，此时必须先加热粘贴面。
- 粘贴时用力压紧，但是要避免损坏用品以及车辆零件。
- 请不要拔出双面胶重新再贴。否则会造成破损，或者双面胶和贴膜不能充分粘紧。
- 安装后 24 小时之内请不要让安装位置沾水。

组成配件

电动尾门套件

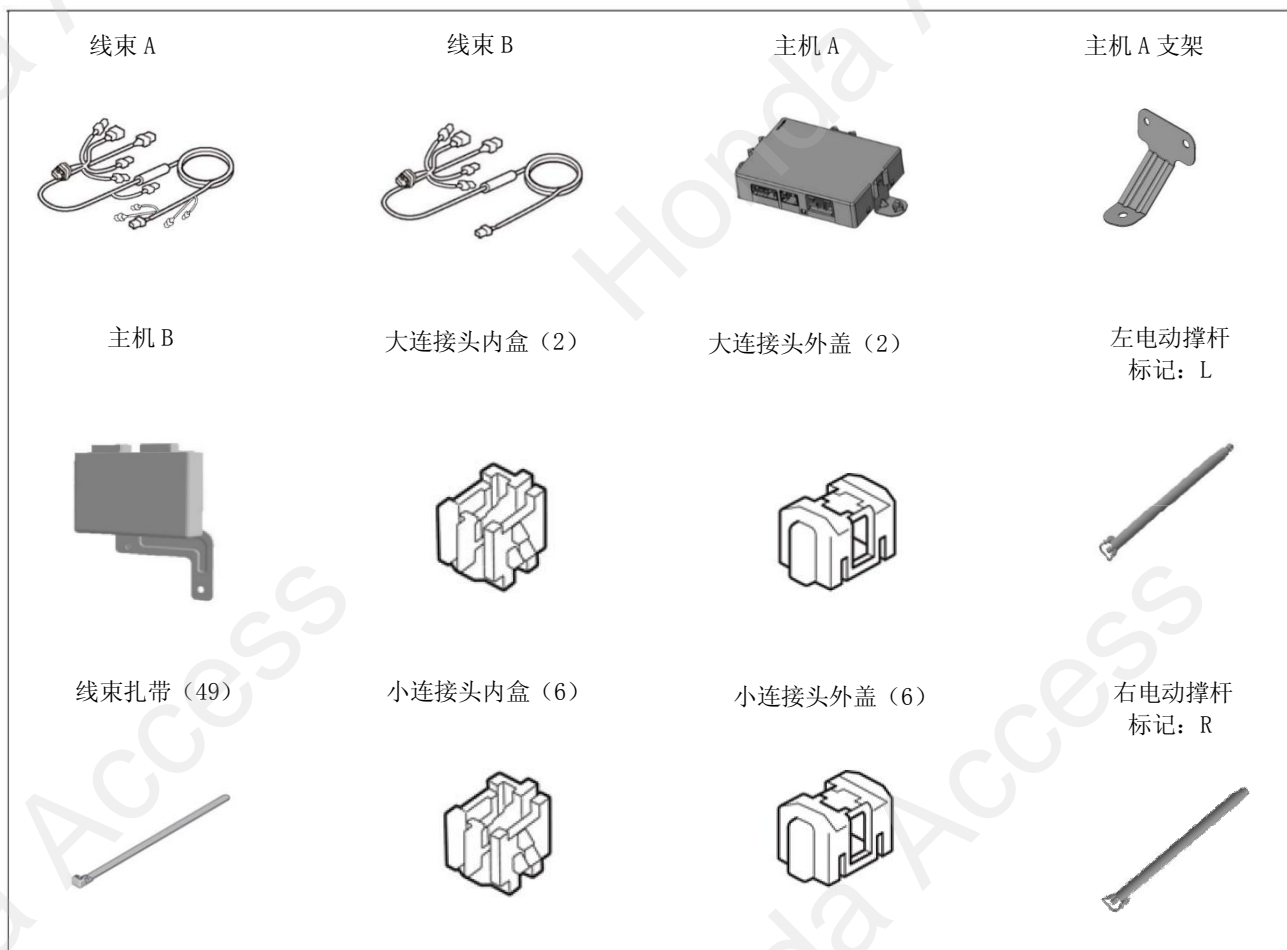

左防夹条



右防夹条



左侧门支架

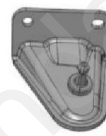

右侧门支架

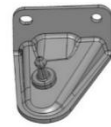

铝箔纸 (7)



室内开关



螺丝 (6)



螺丝 (2)



防水螺母 (2)



定位纸板

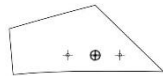

波纹管 (2)

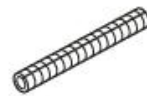

5.5*3垫片 (2)



安全气囊夹扣



尾门吸合锁



防夹条的螺栓(6)



泡棉 (4)



尾门吸合锁螺栓



主机A螺母 (2)



门拉手螺丝 (2)



门拉手接线器



门拉手饰件



钣金支架 (左)



钣金支架 (右)



法兰螺栓 (2) 6*8



底涂包 (2)

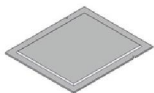

使用说明书



必要工具/用具

- 扳手
- 棘轮
- 十字螺丝刀
- 绝缘胶布
- 包封胶布
- 电钻
- 六角扳手
- 脱脂洗洁剂
- 套筒
- 镊子
- 卡尺
- 胶布
- 冲头
- 电工胶布
- 抹布
- 夹扣拔取器
- 剪刀
- 钳子
- 钻头
- 胶锤
- 棘轮扳手

安装方法和顺序

脱脂洗洁剂的清洗方法

- 把脱脂洗洁剂喷涂在抹布上，把粘贴面上的油脂、垃圾、污垢全部擦拭干净。

建议

- 请不要把脱脂洗洁剂直接喷涂在粘贴面。
- 请充分干燥后再进行粘贴操作。



电池负极 (-) 端子的断开

1. 断开电池的电源前请执行图示的操作。
2. 必要的话记录车辆音响、导航系统等の設定。
3. 断开电池的负极端子。

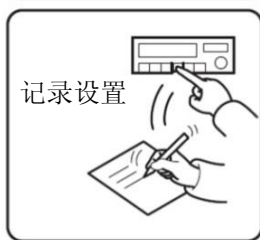
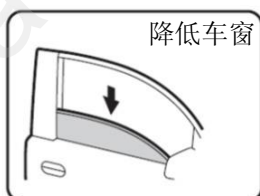

车辆零件的拆卸

4. 拆出方向盘下饰板饰盖。

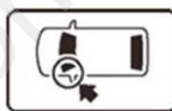

旋钮

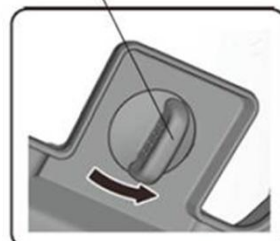

方向盘下饰板饰盖

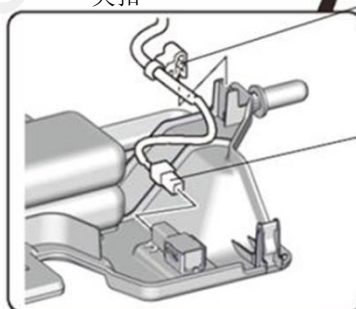
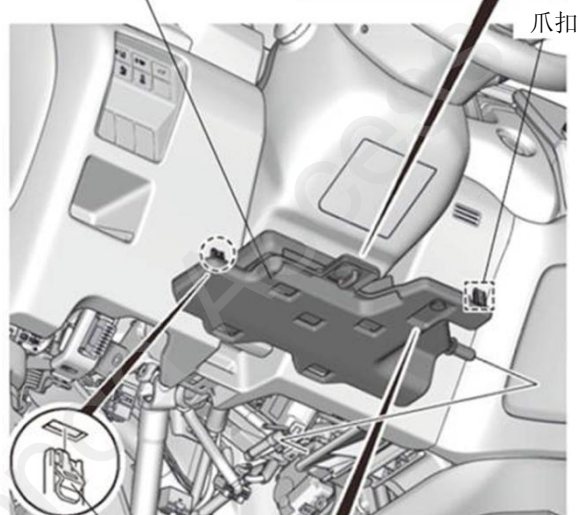

<配备脚边照明灯的车型>

5. 拆出方向盘下饰板。

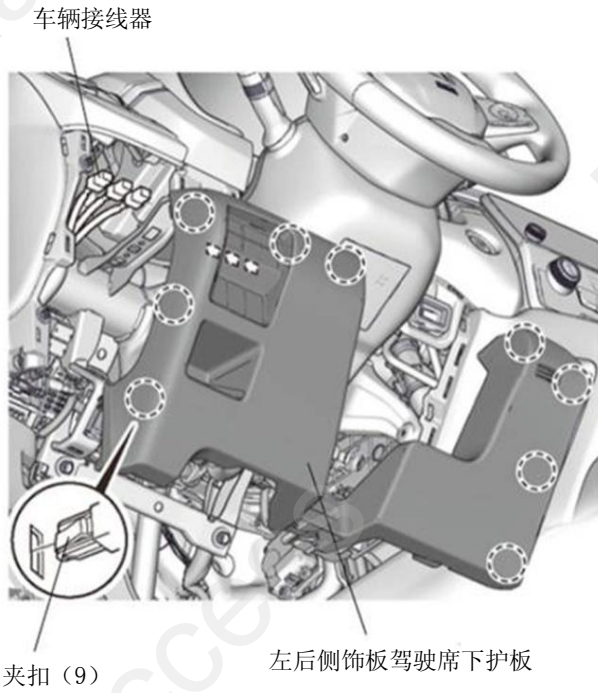

6. 拆出左前门踏板饰板。

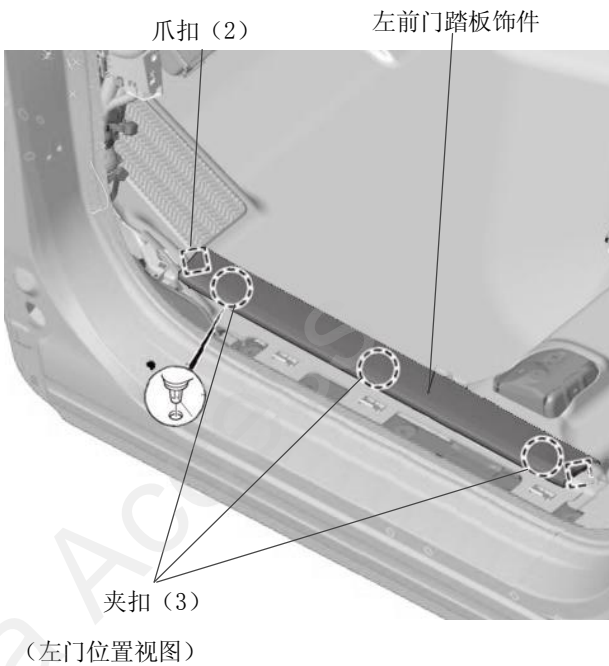

7. 拆出左前侧饰板。

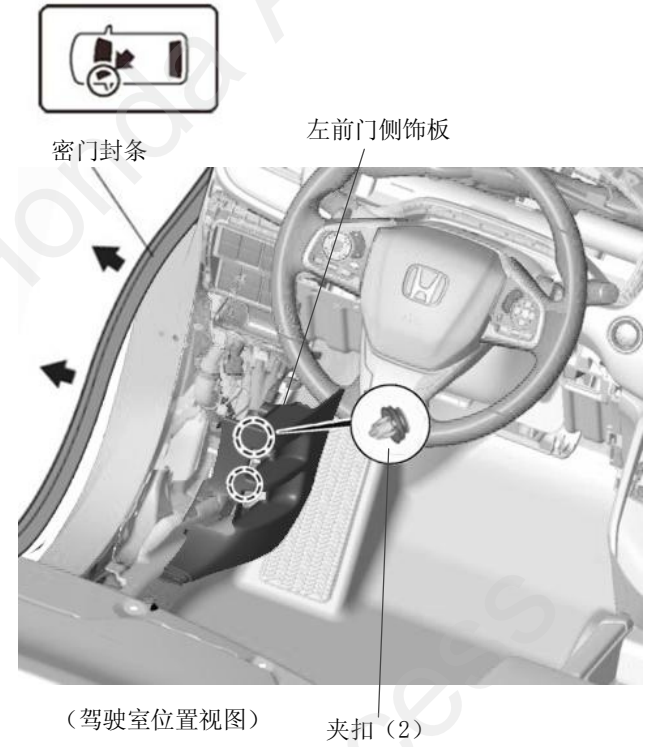

汽油机配置车型转顺序 10

• 混合动力配置车型	顺序 8-9
• 汽油机配置车型	转顺序 10

<混合动力配置车型>

8. 拆出按键面板。

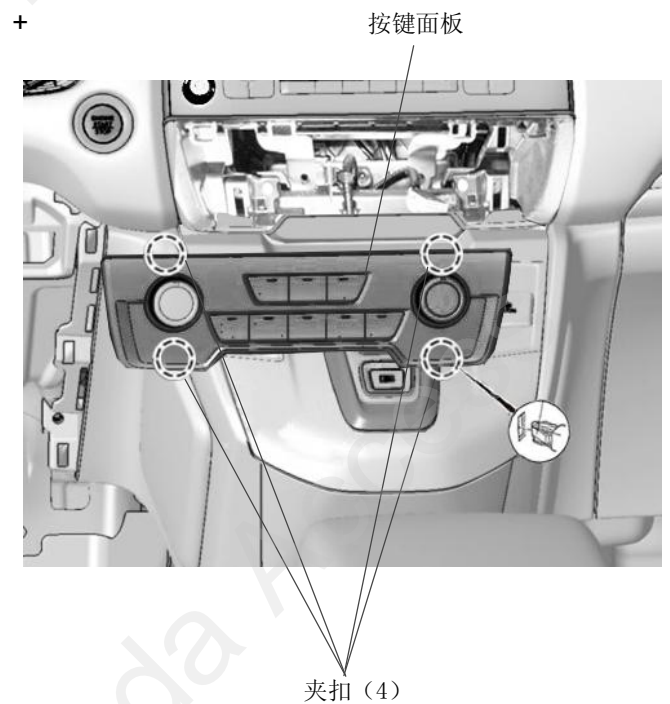

9. 拆出中控台面板。

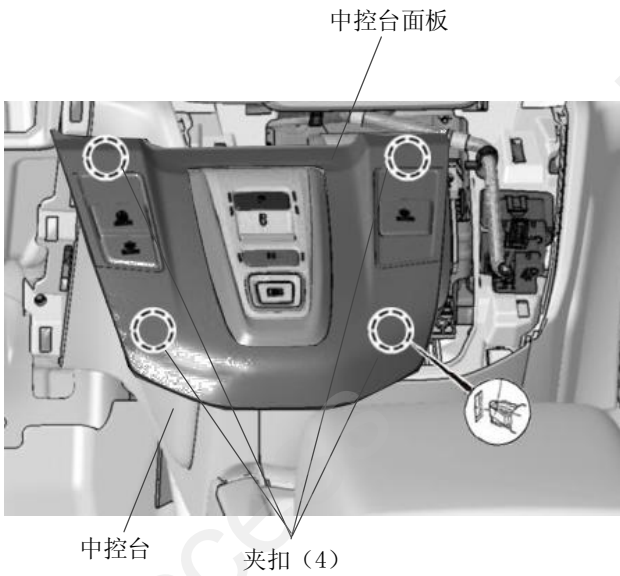
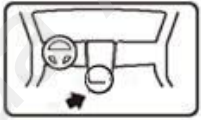

10. 拆出左后侧踏板饰件。



11. 拆出左侧中立柱下护板。

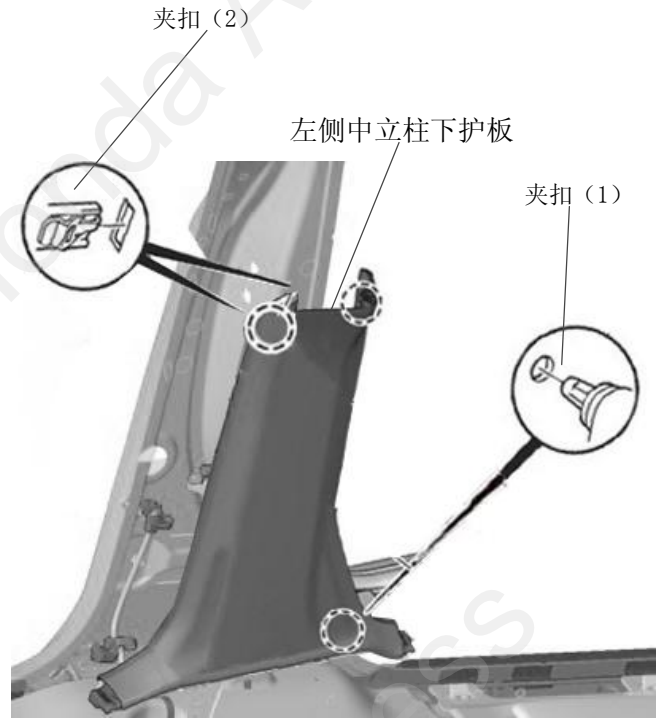

12. 打开尾门，拆出后尾箱遮阳帘。

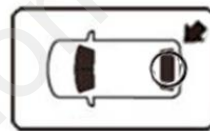

卡位
(推进去) 端盖

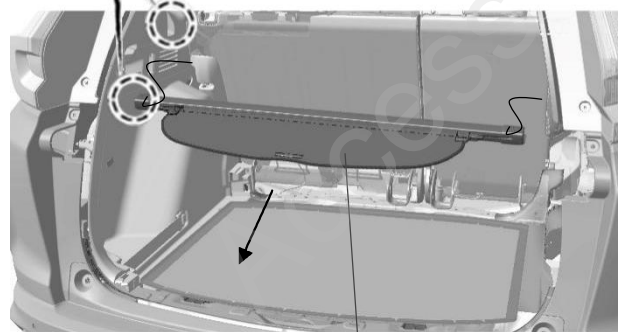
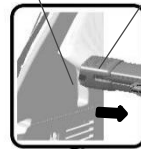

(尾门位置视图)

后尾箱遮阳帘

- 混合动力配置车型
- 汽油机配置车型

顺序 13-15
转顺序 16

〈混合动力配置车型〉

13. 向前放倒左后排座椅。

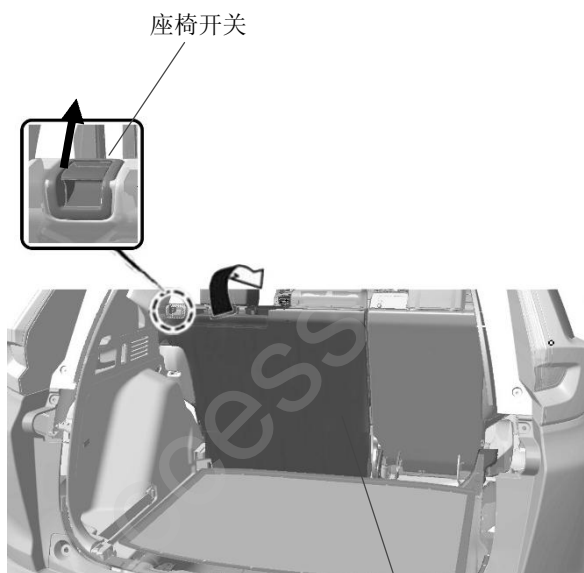

左后排座椅

14. 拆出座椅靠背下的固定钩。

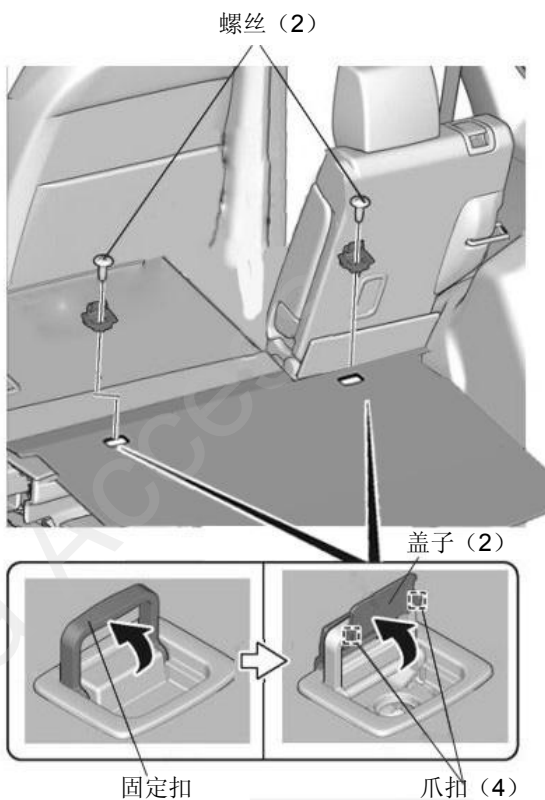

15. 拿出行李箱垫板。

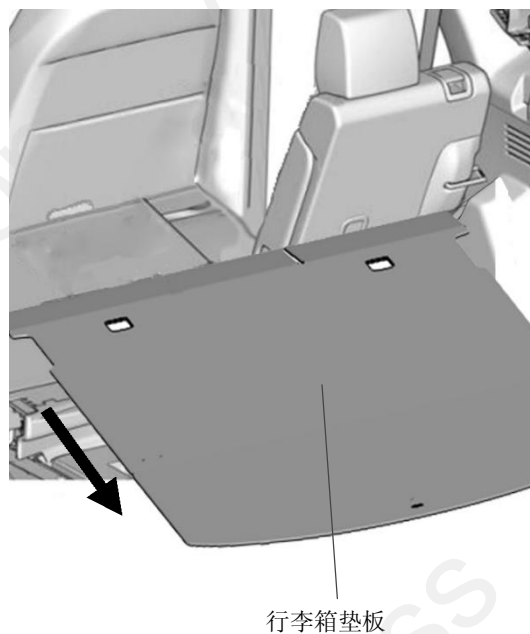

转顺序 21

〈汽油机配置车型〉

16. 拿出行李箱垫板。

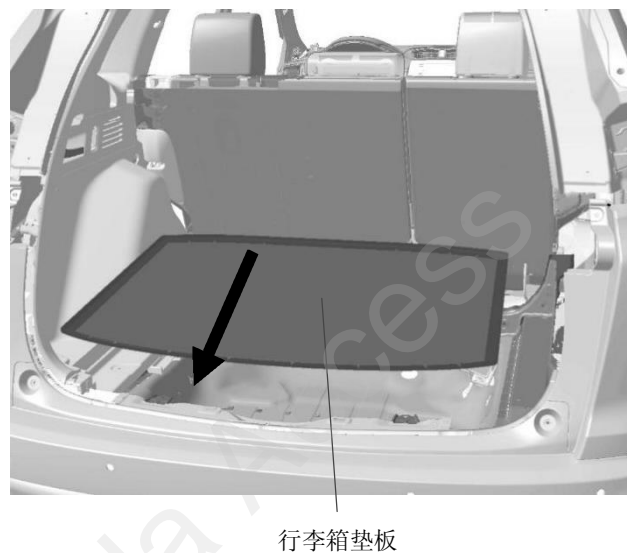

17. 向前放倒左后排座椅。

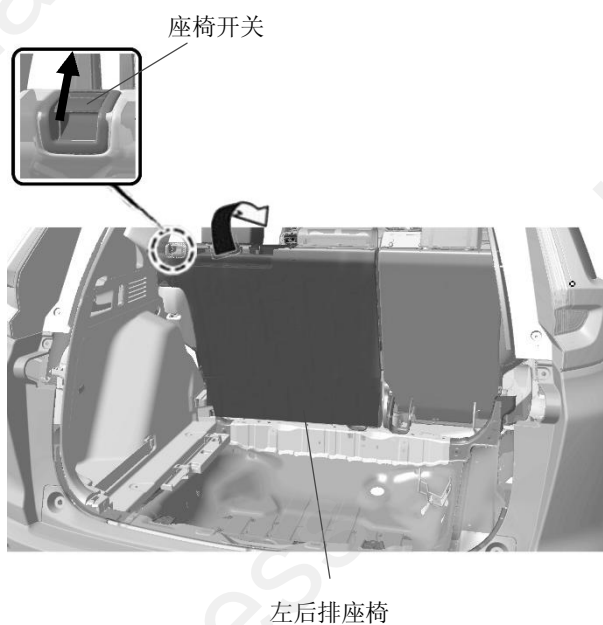

19. 拆出座椅靠背下饰件。

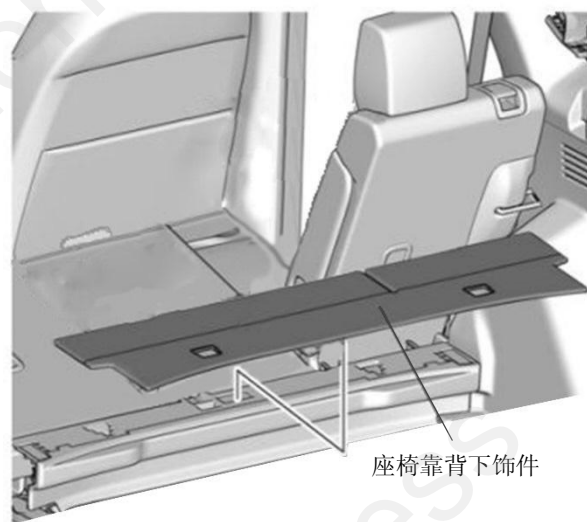

18. 拆出座椅靠背下的固定钩。

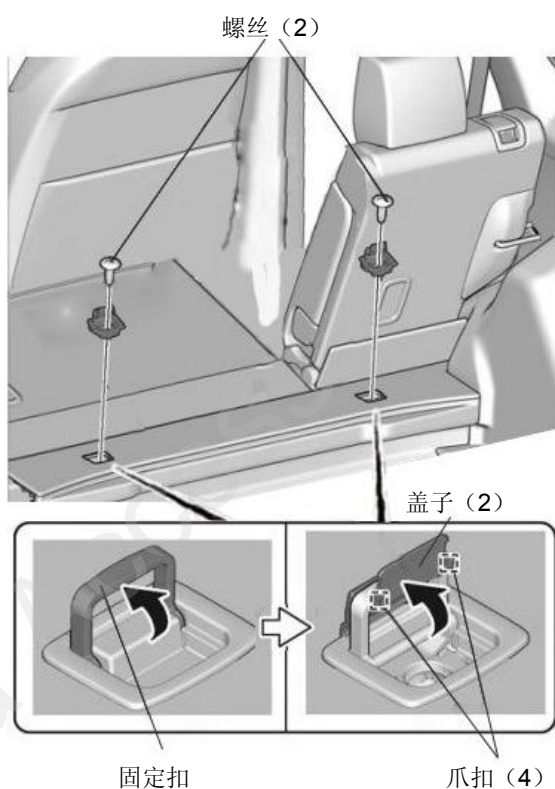

20. 拆出地毯盖。

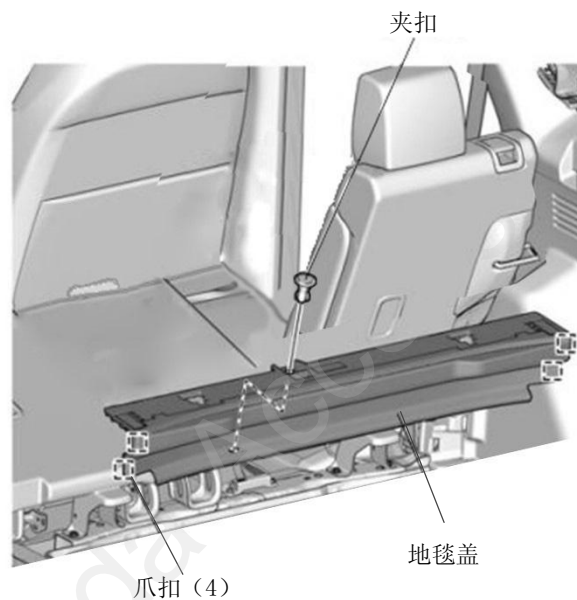

21. 拆出后尾箱饰件。

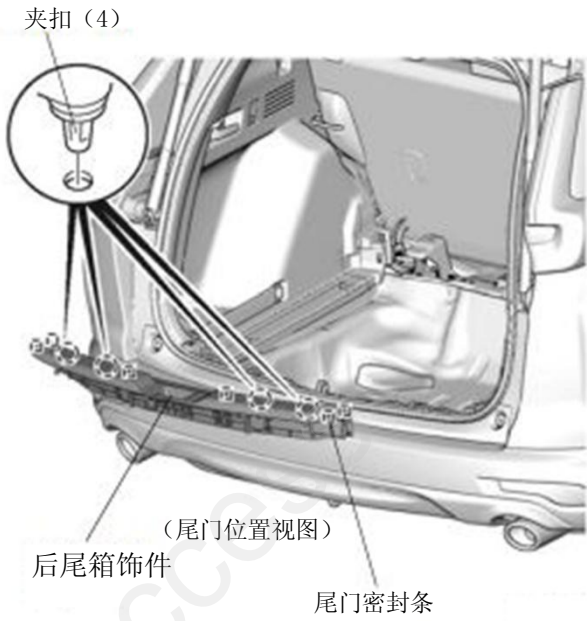

22. 拆下内手柄盖和螺丝。

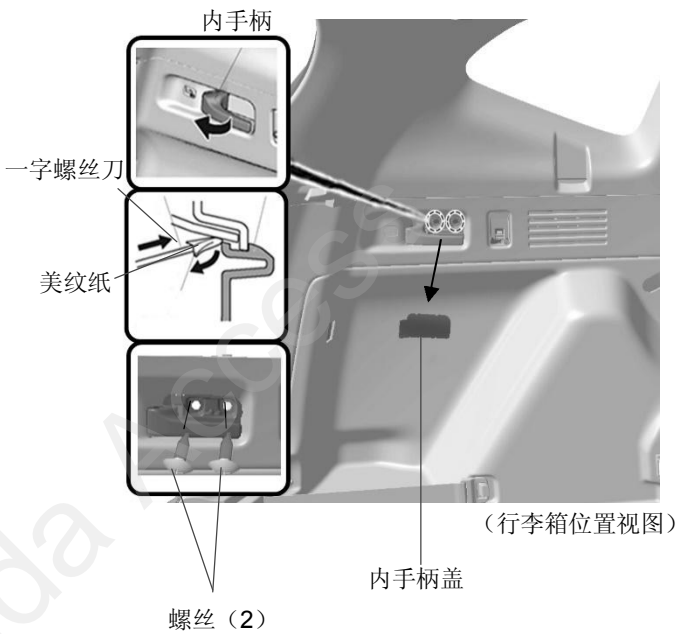
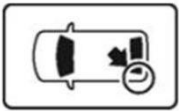

23. 拆下固定钩和螺丝。

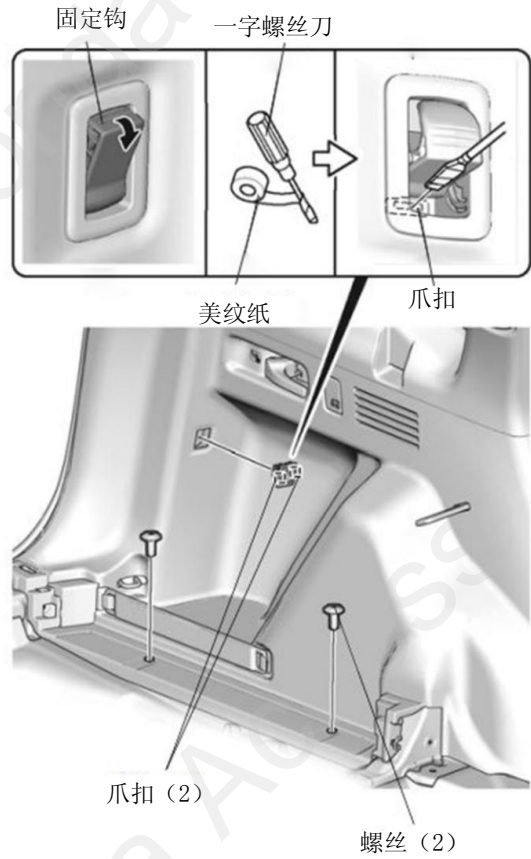

24. 拆出后尾箱左后下内饰件。

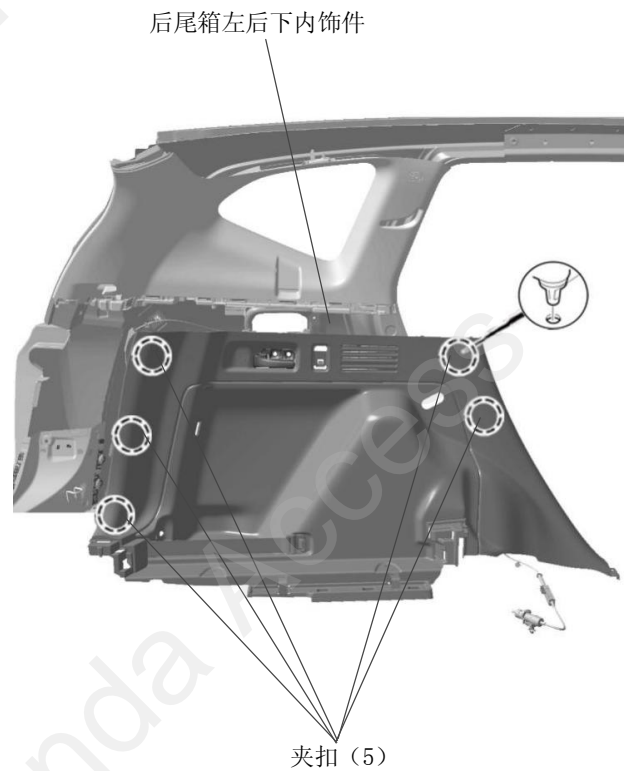

25. 拆出尾部顶棚饰板。

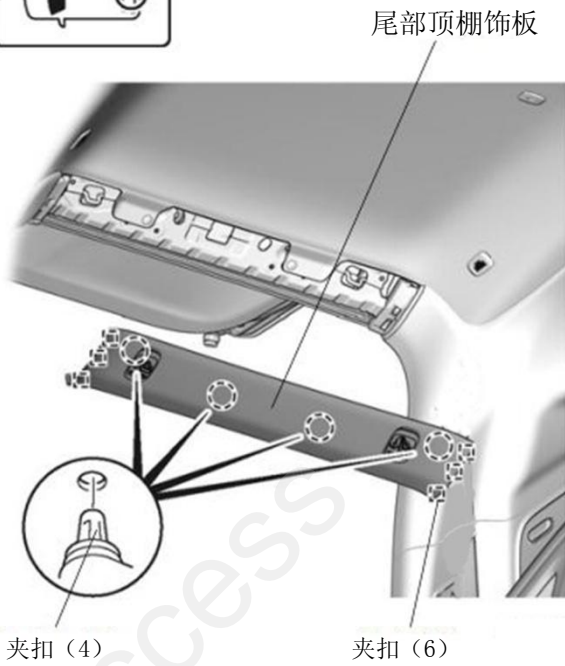
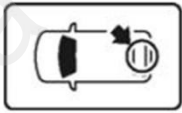

26. 使用橡胶锤轻击 C 柱饰件推入夹扣。

建议

- 请将橡胶锤垂直轻击 C 柱。

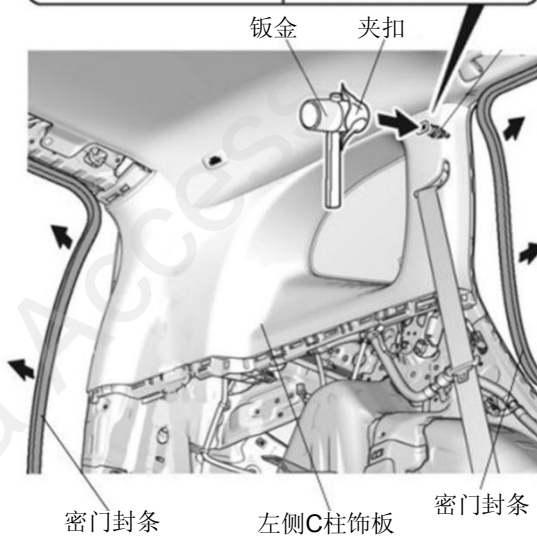
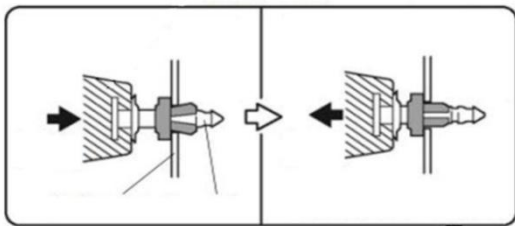
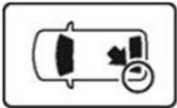

27. 拆出左侧 C 柱饰板。

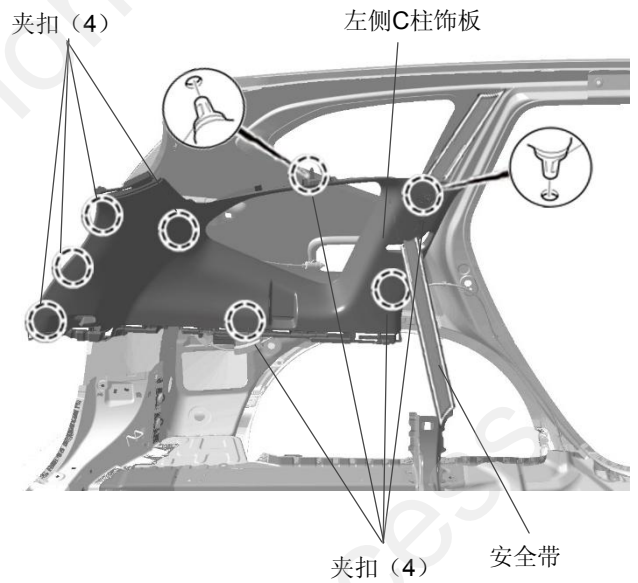

拆出后保险杠饰件

28. 拆出左侧挡泥板。

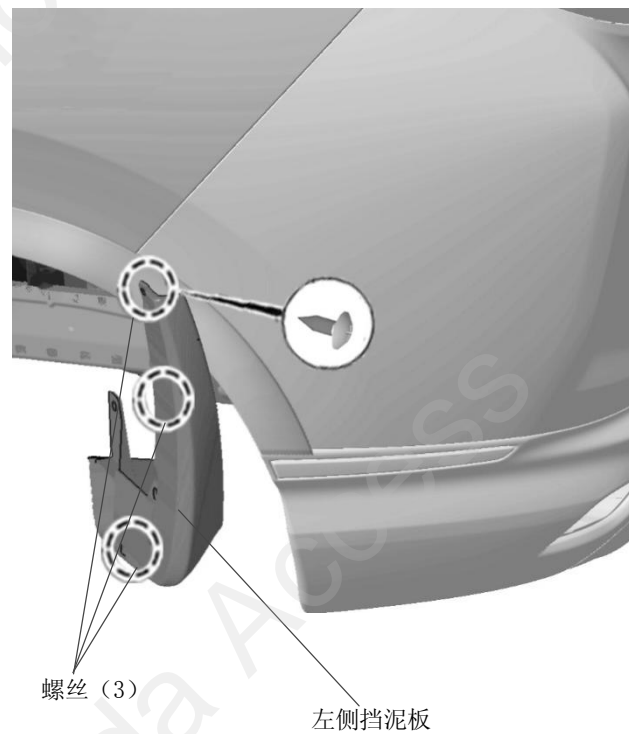

29. 拆出左侧轮眉上螺丝。

30. 拆出左侧轮眉。

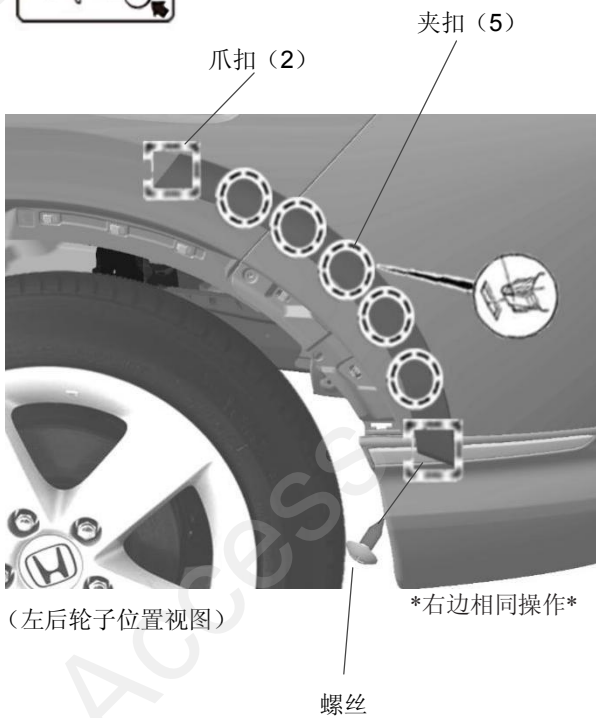
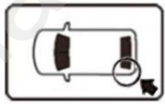

31. 保险杠上粘贴防护胶布。

注意

- 复原操作完成后才能撕掉胶布。

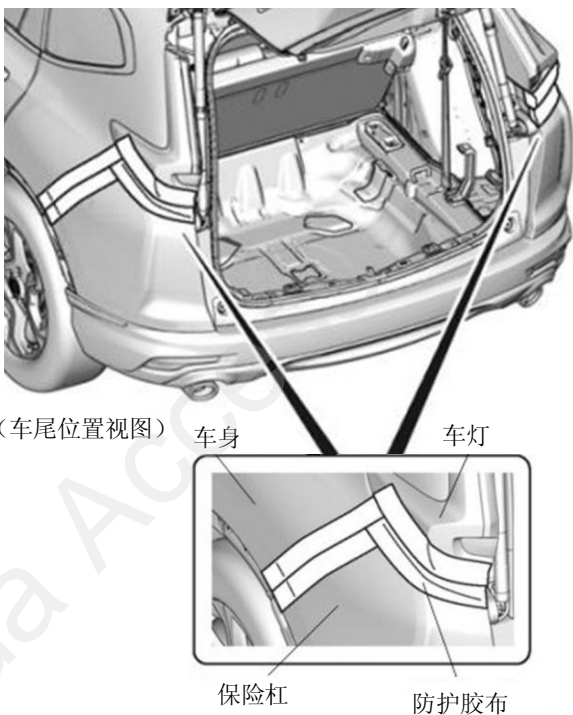
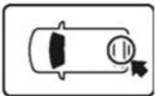

32. 拆出夹扣，螺丝，螺栓。

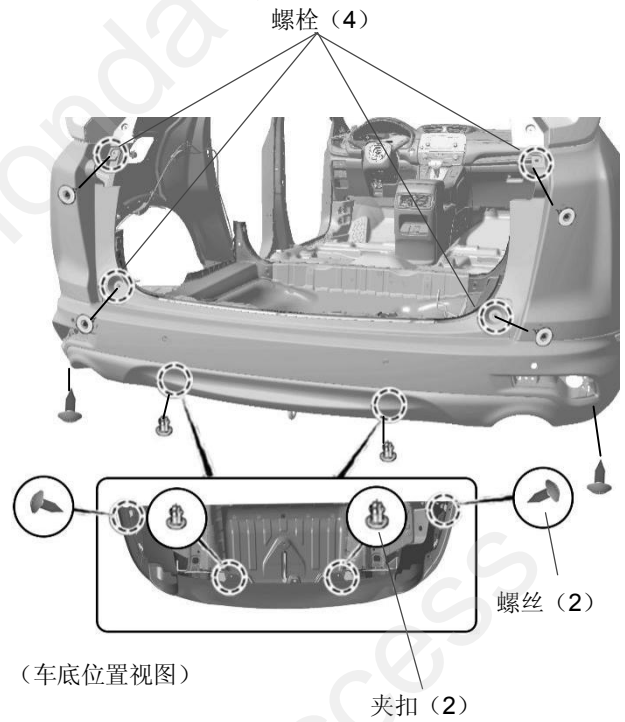

33. 拆出保险杠上螺丝，卡扣和爪扣。

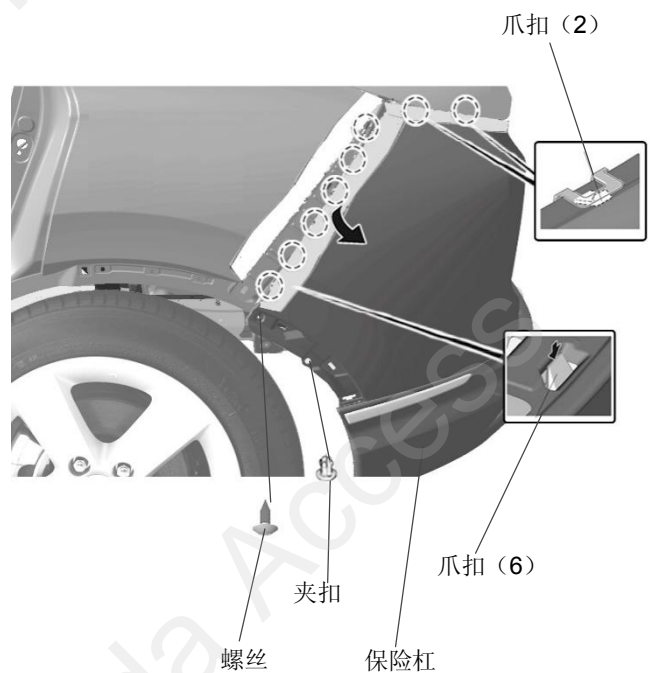
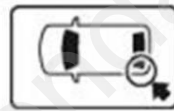

34. 拆出保险杠。

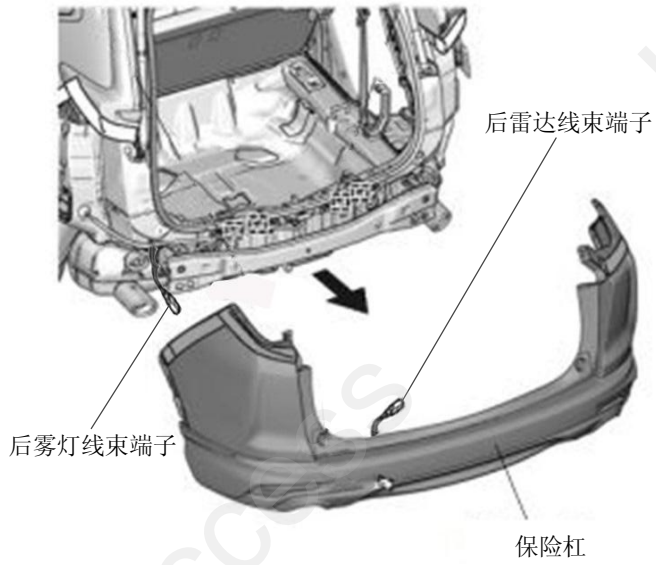
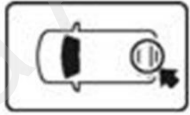

36. 拆出尾门左右饰件。

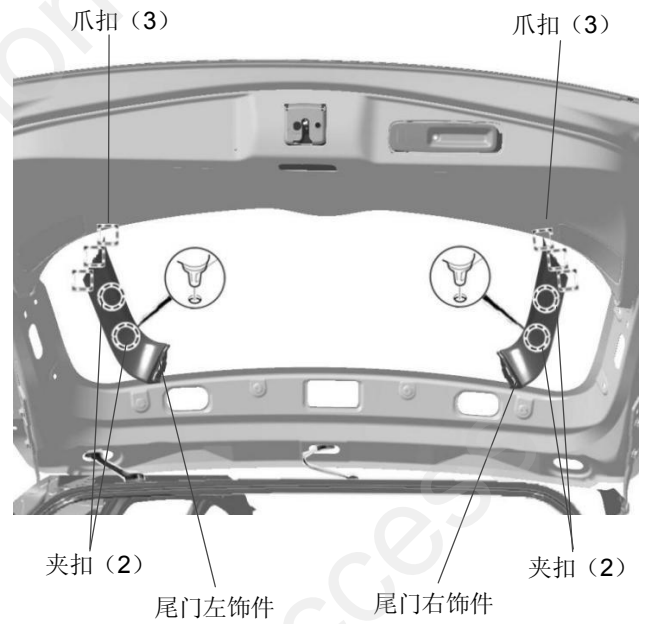

35. 打开尾门，拆出尾门下饰件。

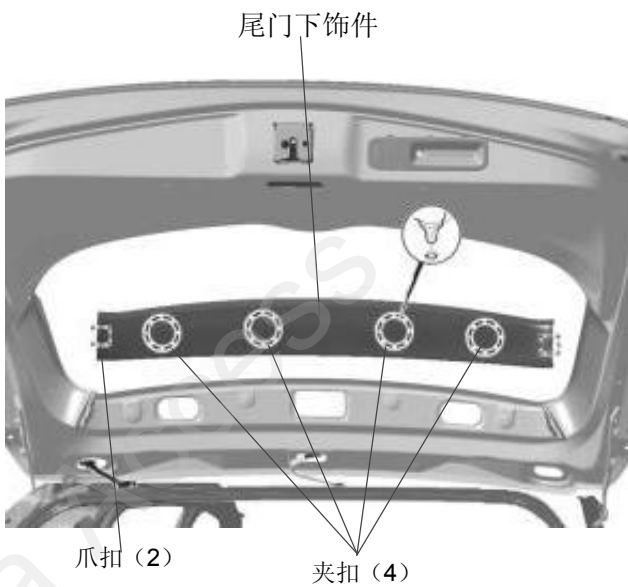
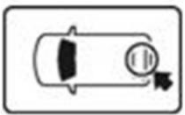

(后门下位置视图)

37. 拆出尾门拉手。

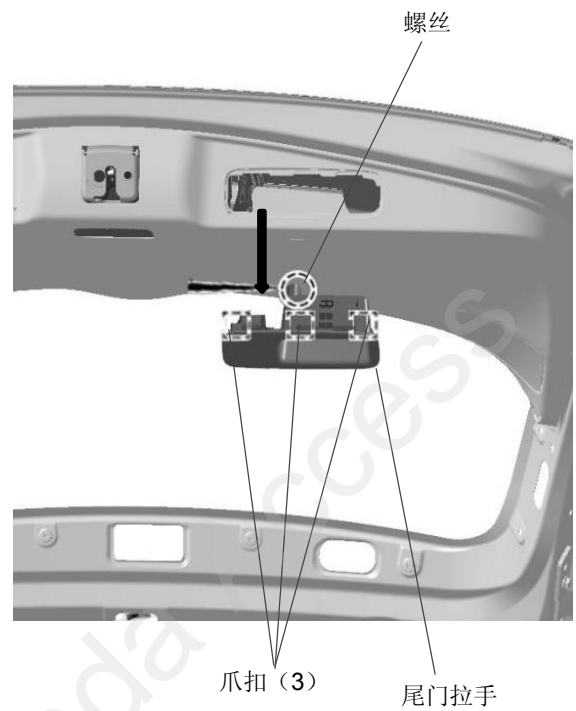

38. 拆出尾门内饰件。

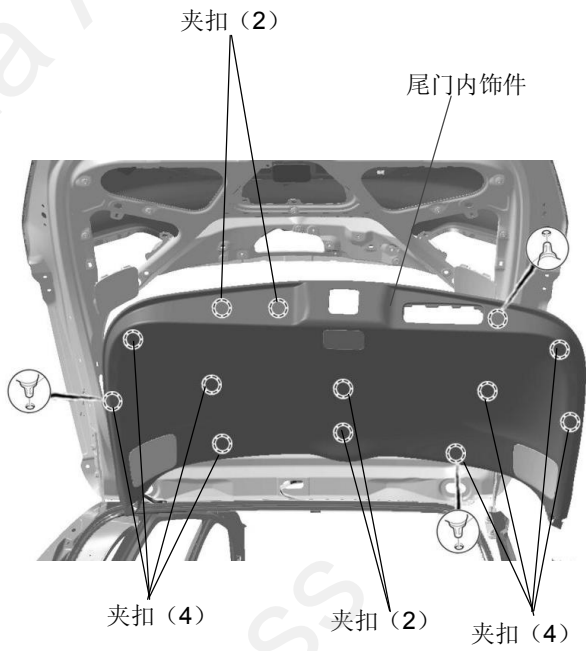

39. 拆出门锁。



40. 拆出原车左右电动撑杆。



注 意
• 尾门需要两个人进行拆装工作,要十分注意安全。

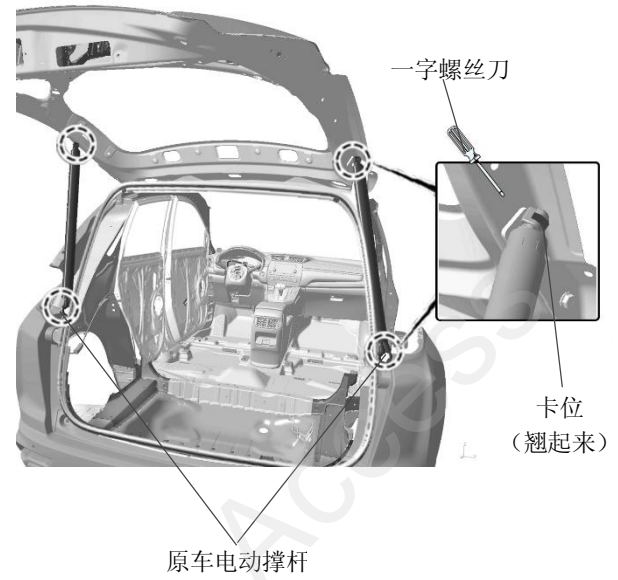

41. 拆出原车螺丝。

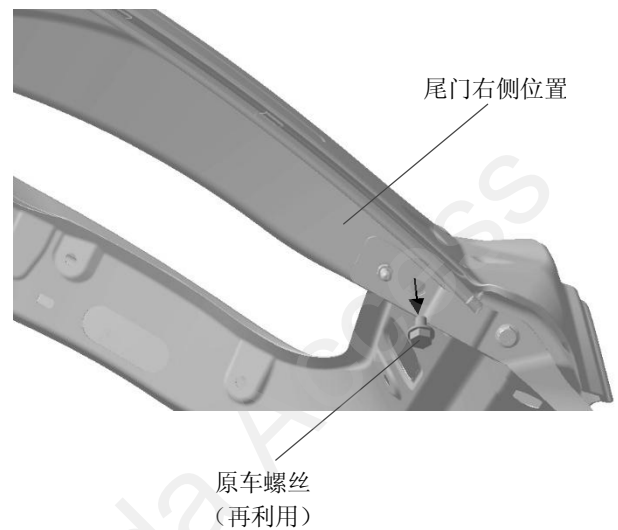

42. 安装钣金支架定位打孔。

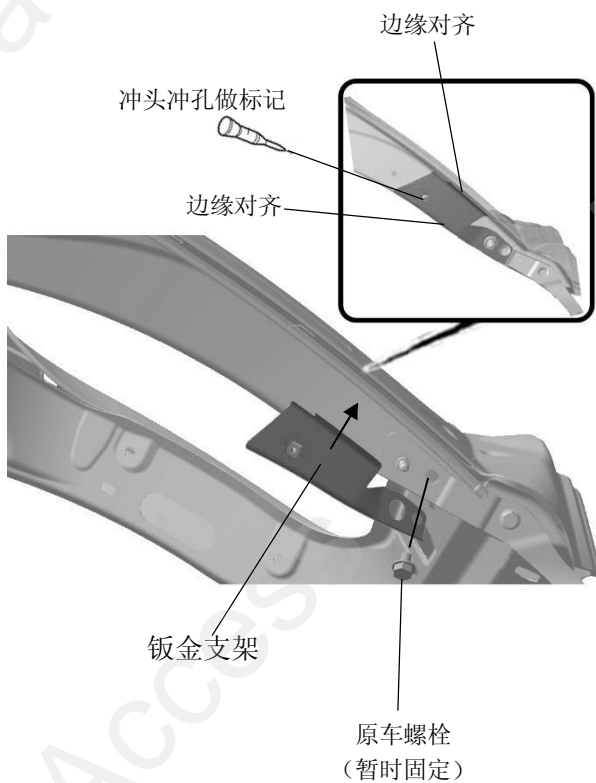

43. 拆出钣金支架，使用电钻打孔。



44. 固定安装钣金支架，尾门内侧安装支架螺丝。

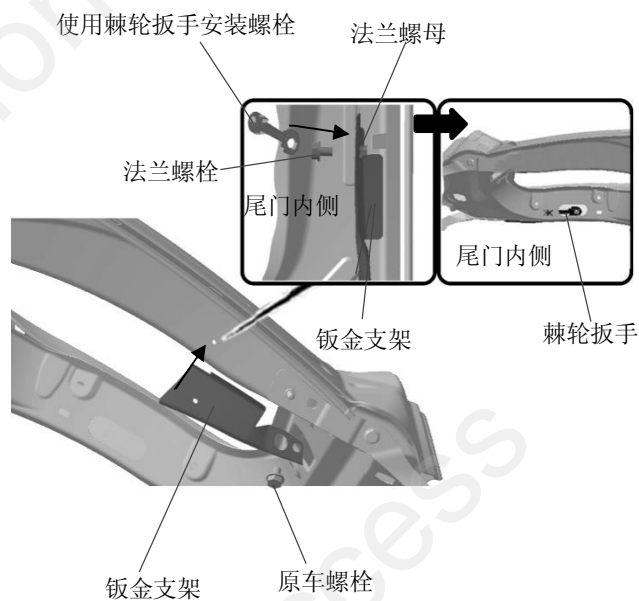

左侧钣金支架进行同样的安装操作

45. 更换左右电动撑杆底座。

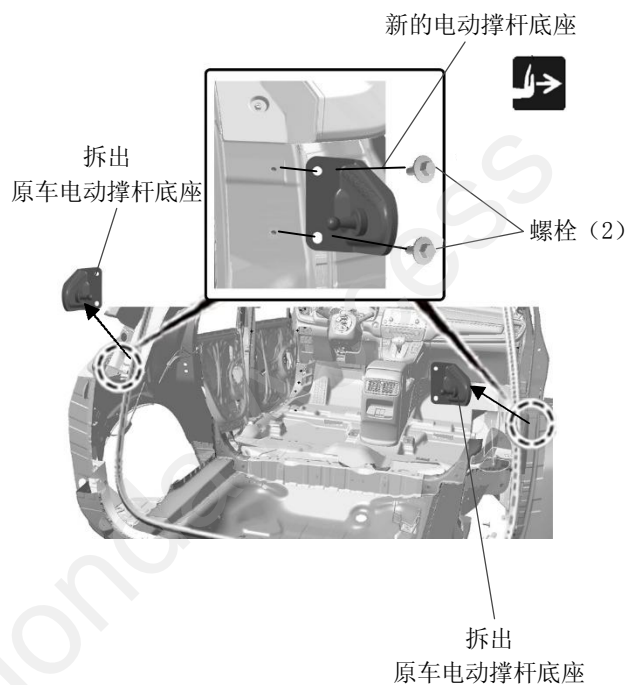

46. 更换电动撑杆。

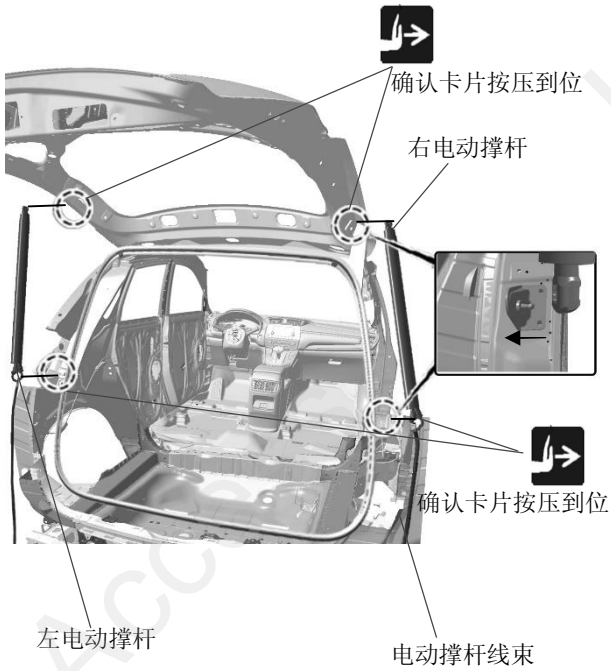

铺放电动撑杆线束

47. 拔出左侧防水塞，铺放线束。



铝箔纸 (2)
除脂

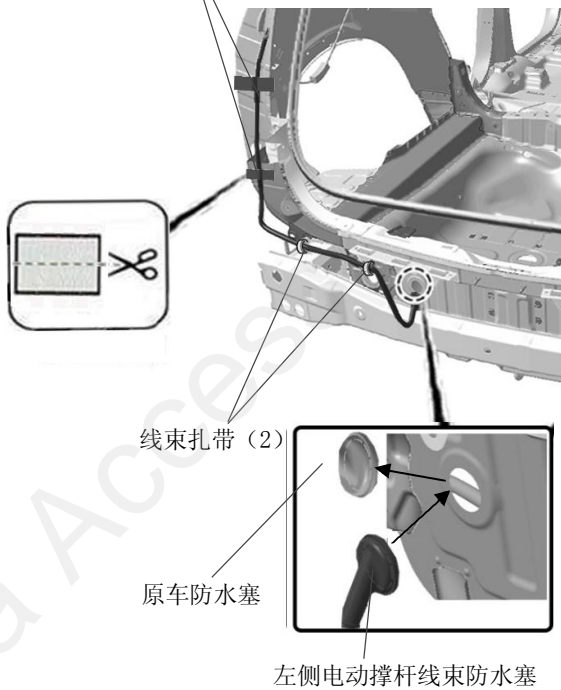

48. 拔出右侧防水塞，铺放线束。

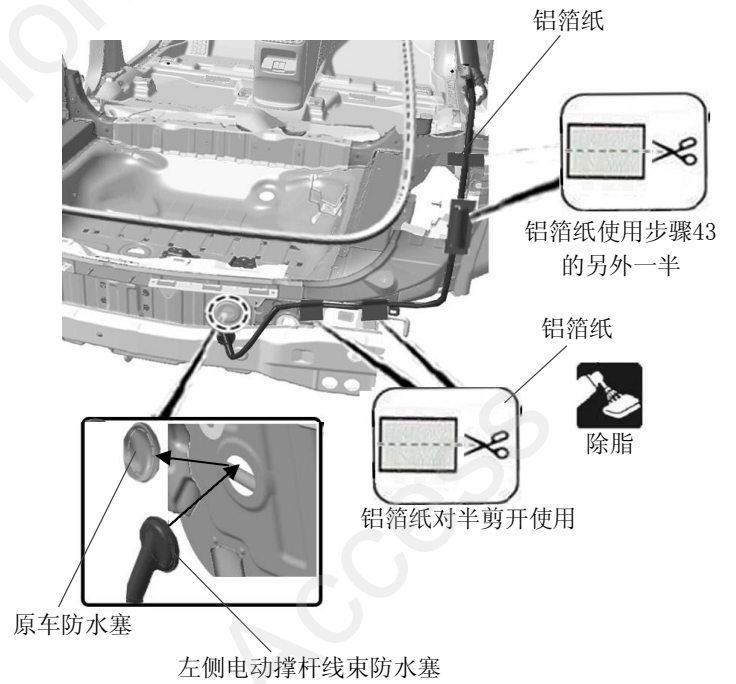

49. 掀开行李箱内板，铺放线束。

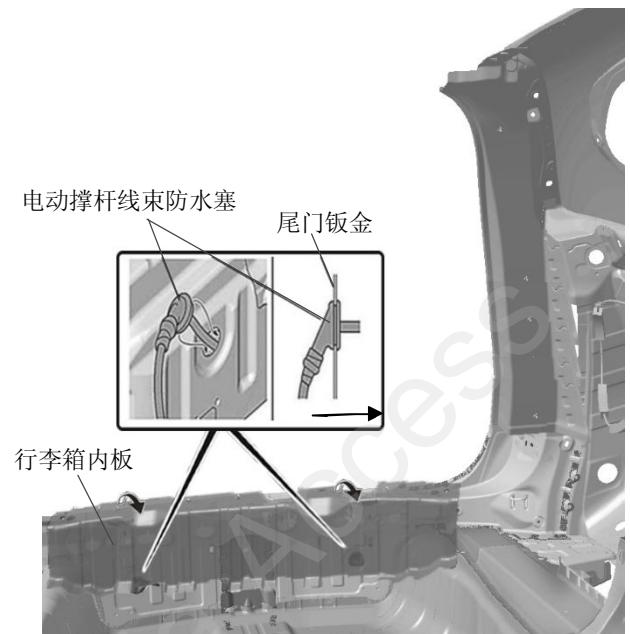

50. 铺放车内电动撑杆线束。

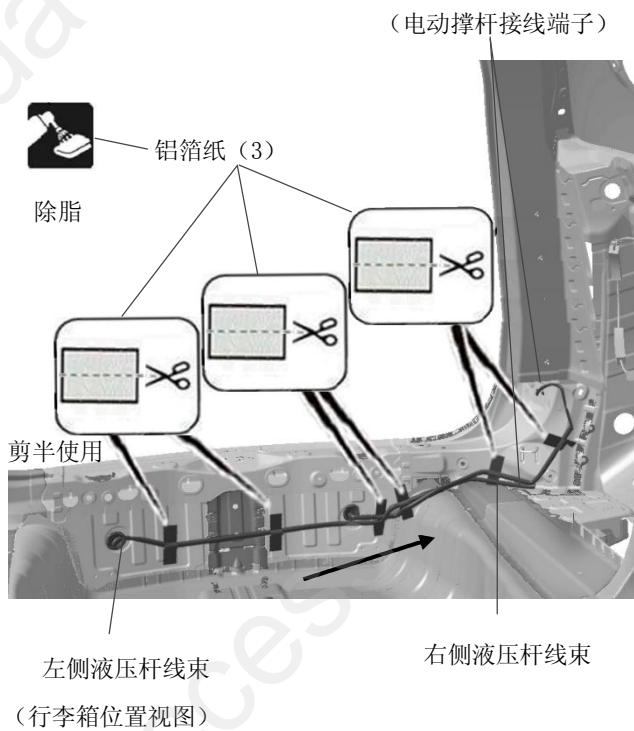

52. 使用钻头开孔（先用小钻头的打孔再用大的钻头打孔）。

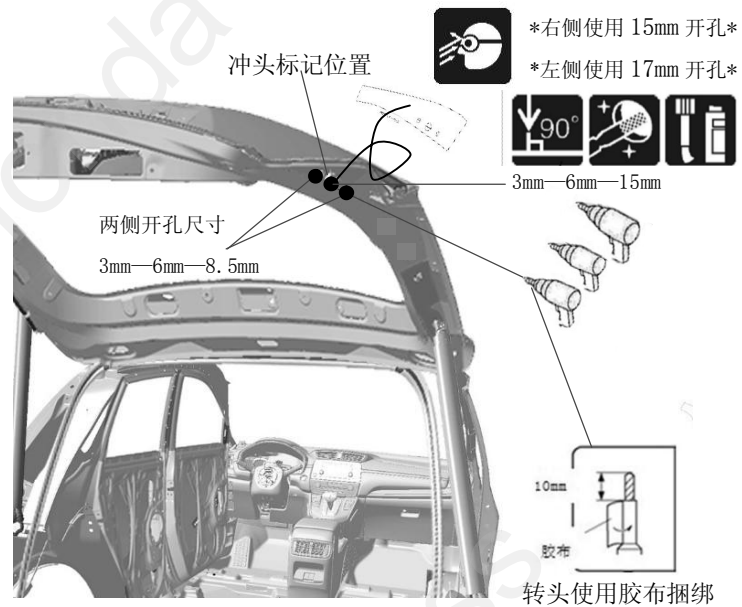

安装右侧防夹条

51. 定位纸板做标记开孔。

注意

- 先用剪刀剪切定位纸板，再使用定位纸板做记号。
- 再用冲头冲孔做标记。
- 再使用转头开孔。
- 开孔后进行防锈漆处理，待充分干燥后再进行下一步操作。

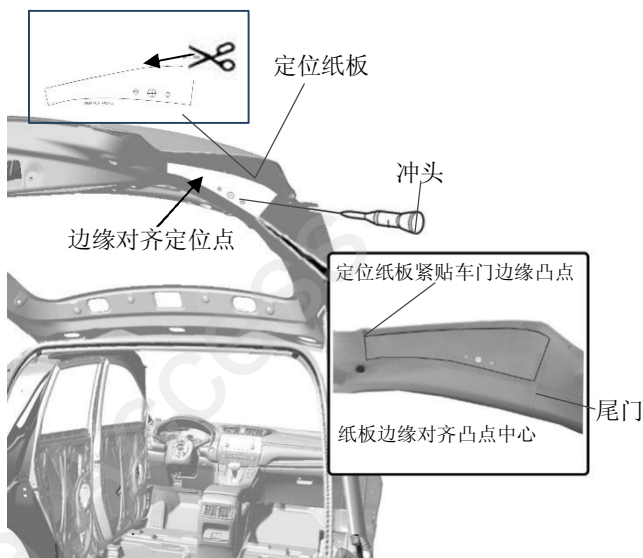

53. 安装右侧防夹条进行定位，使用冲头开孔做标记。

注意

- 先安装防夹条做记号。
- 再使用冲头开孔做标记。

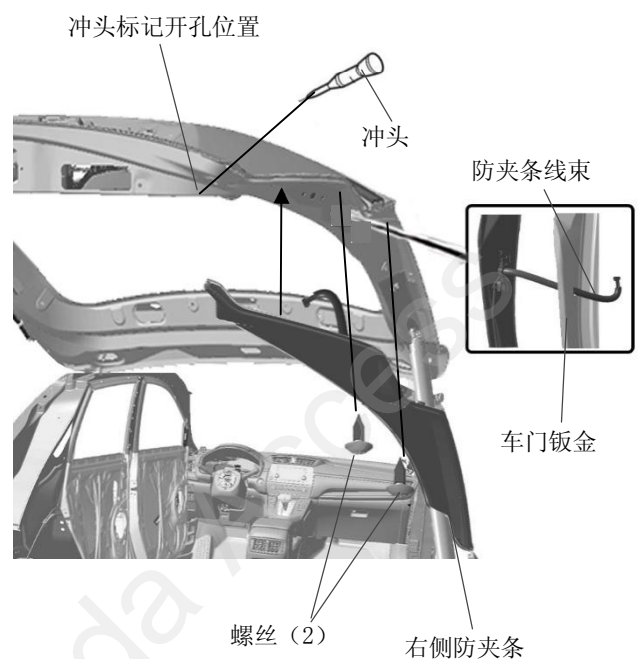

54. 拆出防夹条进行打孔。

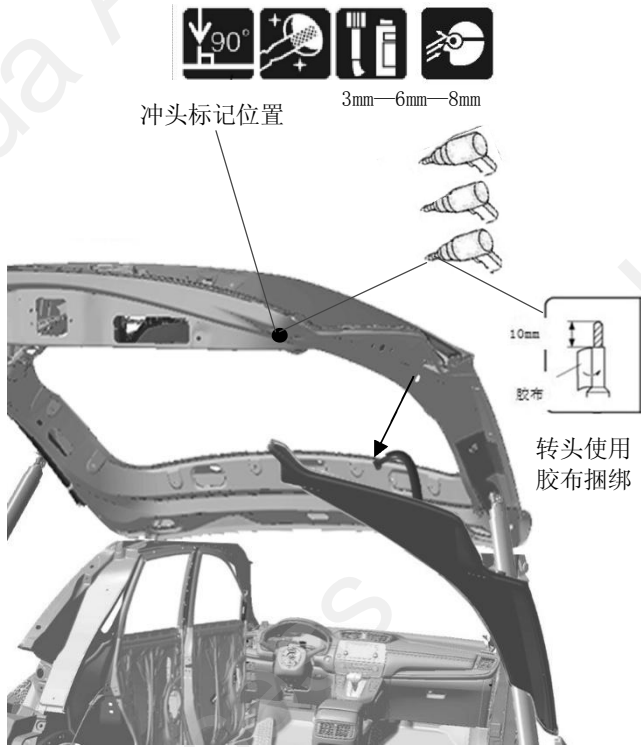

拆出防夹条后打孔

56. 撕掉防夹条上双面胶的离型纸。

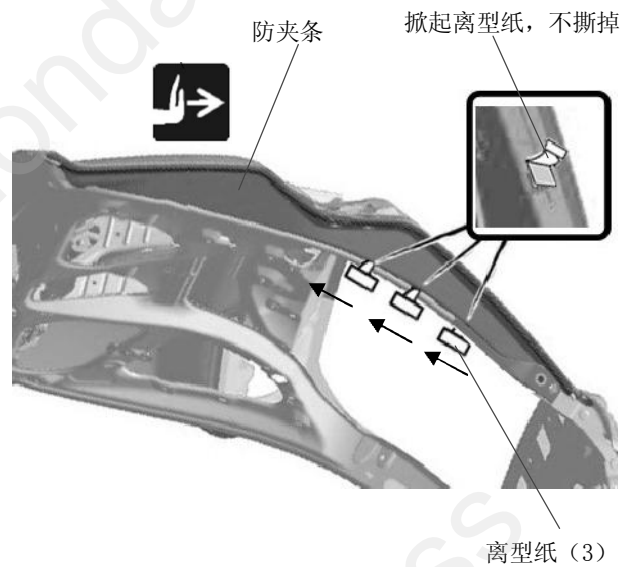

左侧防夹条进行同样的安装操作

55. 除脂, 并安装右侧防夹条。

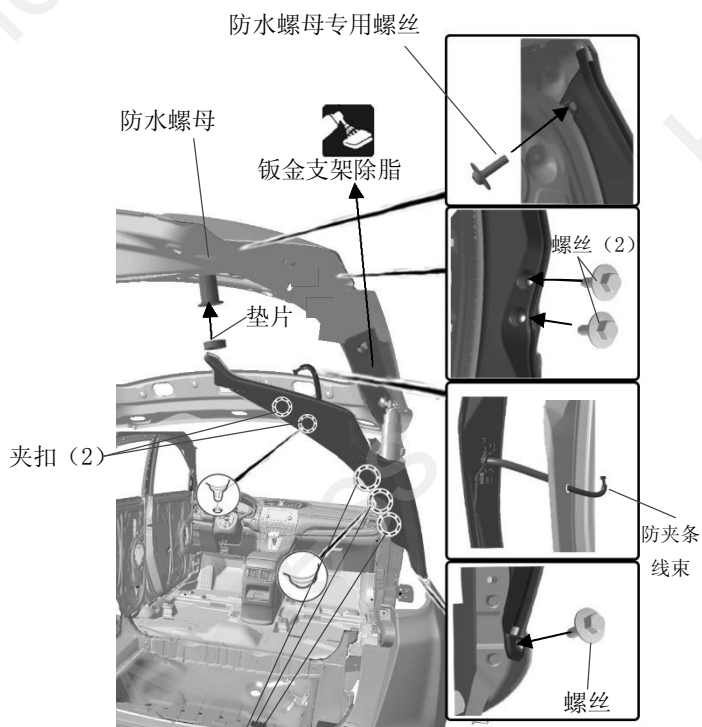

双面胶 (3)
双面胶粘贴位置先除脂再刷N200底涂

铺放门内线束

57. 安装门内主机。

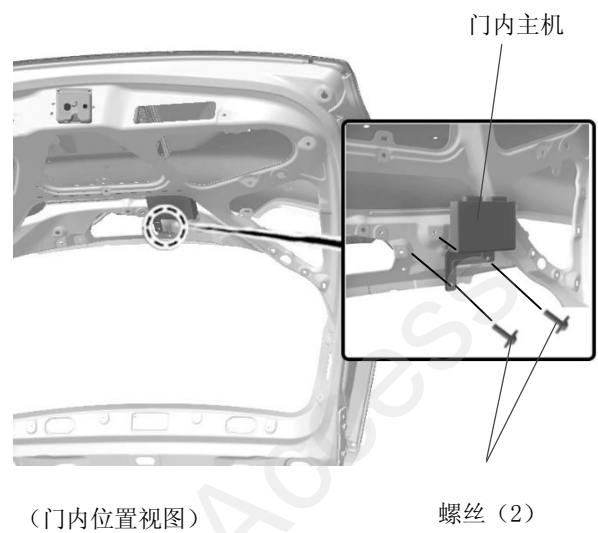

58. 铺放门内主机线束，连接防夹条接线器。

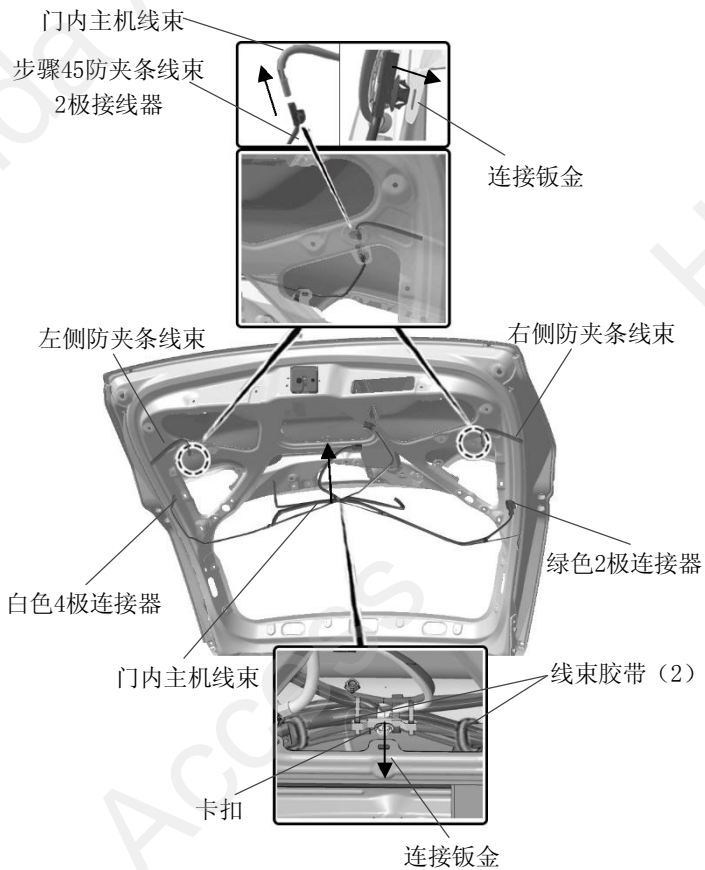

59. 铺放门内主机线束。

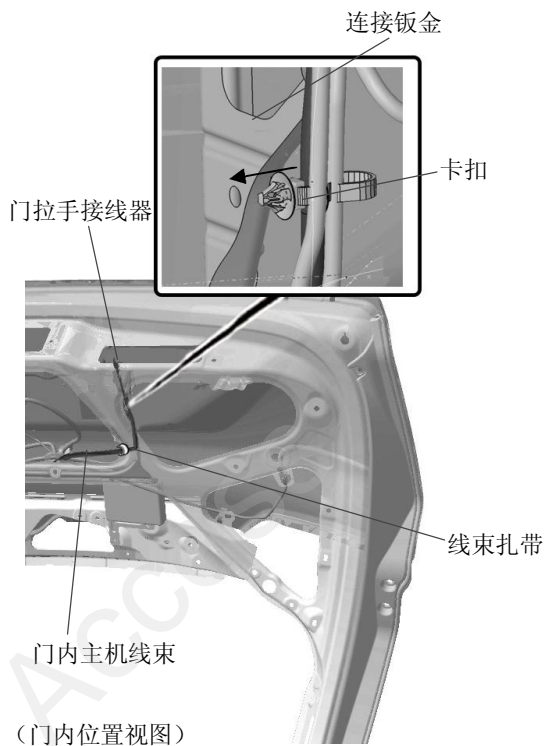

60. 铺放线束，更换门锁，安装门锁 4 极连接器。

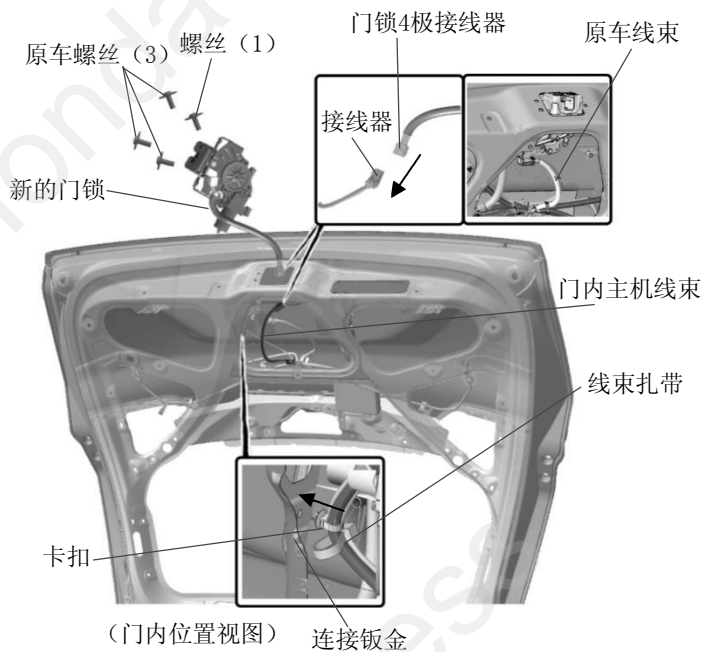

61. 铺放线束，连接原车 4 极以及 25 极信号连接器。

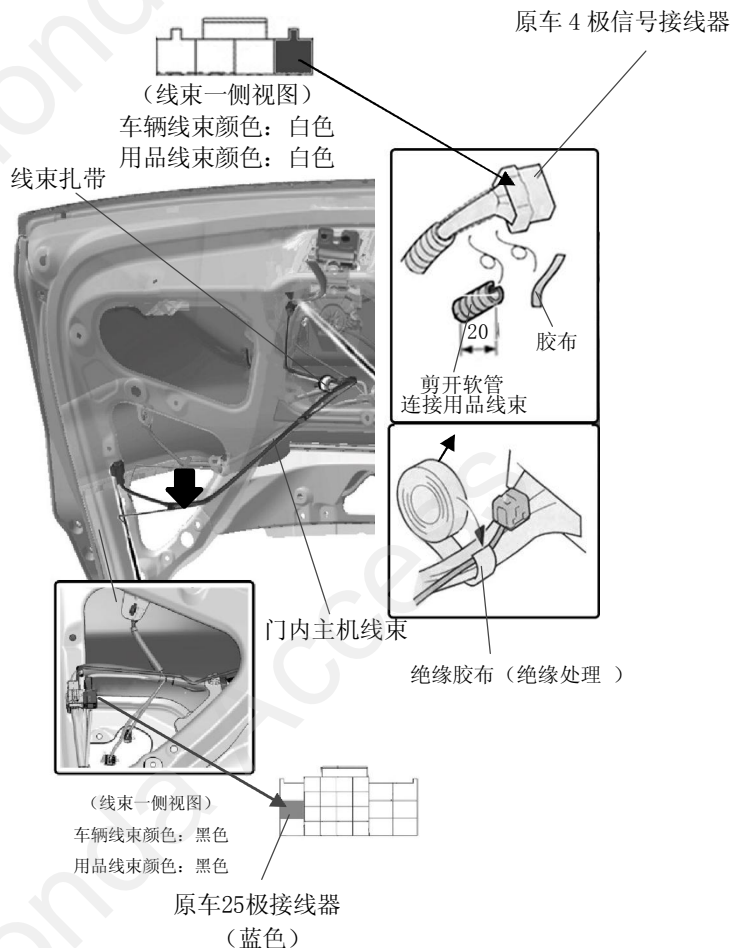

注意

- 连接头的安装方法。

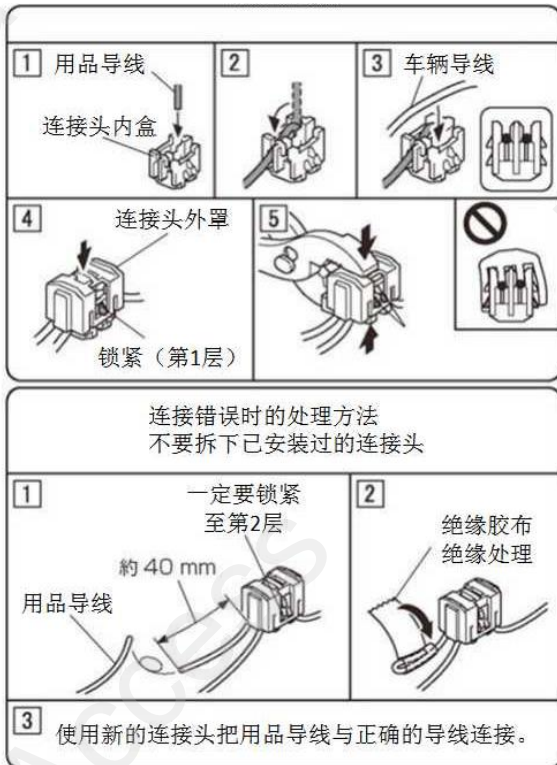

铺放车内线束

62. 安装车内主机。

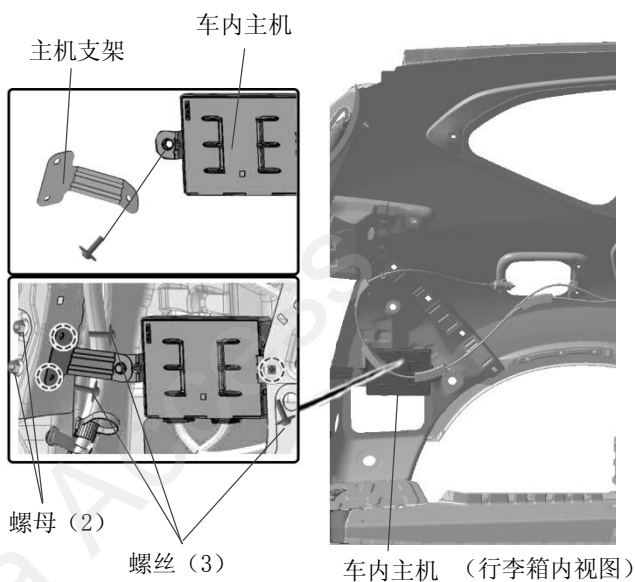
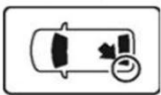

- 混合动力配置车型 顺序 63-64
- 汽油机配置车型 转顺序 65

<混合动力配置车型>

63. 铺放线束。



保险丝盒 方向盘下盖
(驾驶室内视图) (往中控台方向)

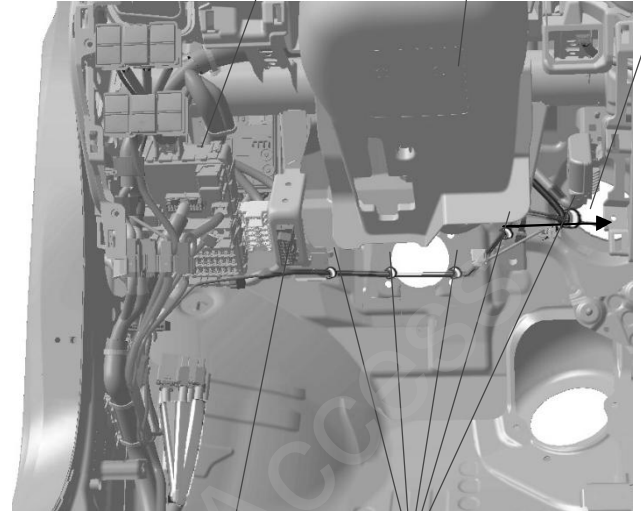

64. 铺放线束, 连接中控台 20 极接线器。

(线束一侧视图)

车辆线束颜色: 绿色

用品线束颜色: 粉色

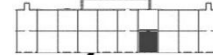

中控台 20 极接线器

连接用品线束

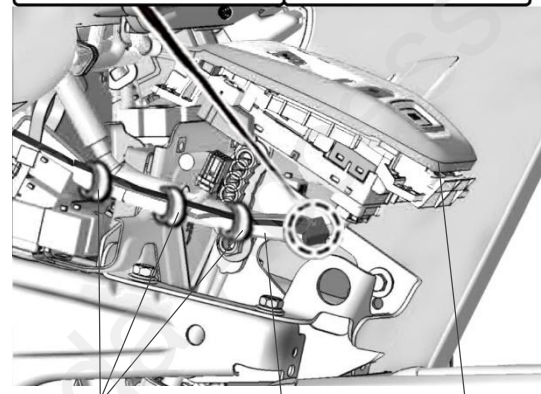
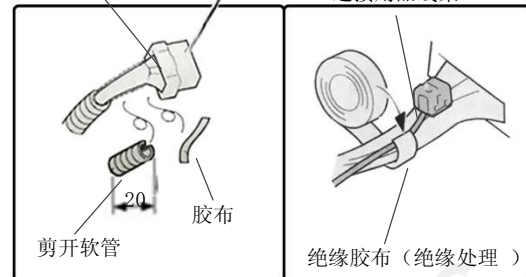

转顺序 68

<汽油机配置车型>

65. 拔出车辆 28 极接线器。

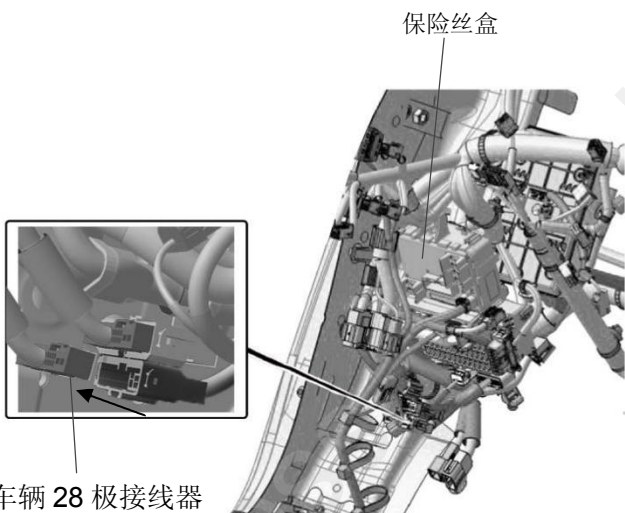

66. 铺放线束，连接车辆 28 极接线器。

(线束一侧视图)
 车辆线束颜色：绿色
 用品线束颜色：粉色

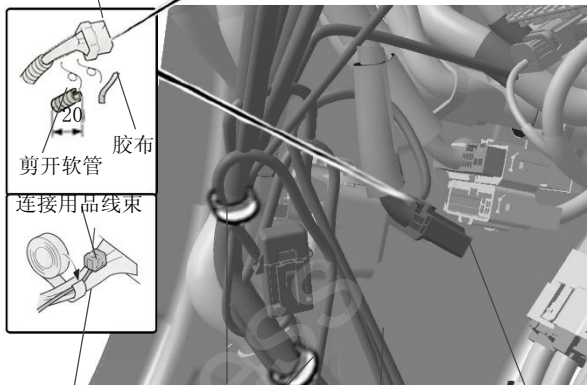
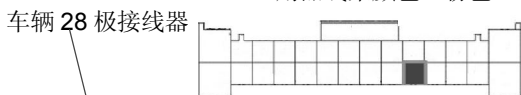

67. 插回车辆 28 极接线器。

68. 拔出连接车辆 27 极接线器，拆出护盖。



69. 铺放线束，连接车辆 27 极接线器。

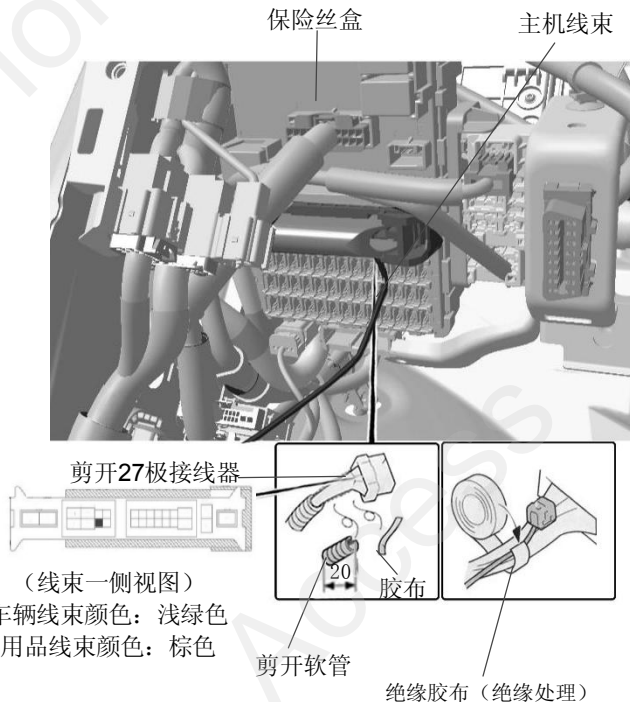

70. 插回车辆 27 极接线器。
 71. 铺放线束，连接车辆 4 极接线器。

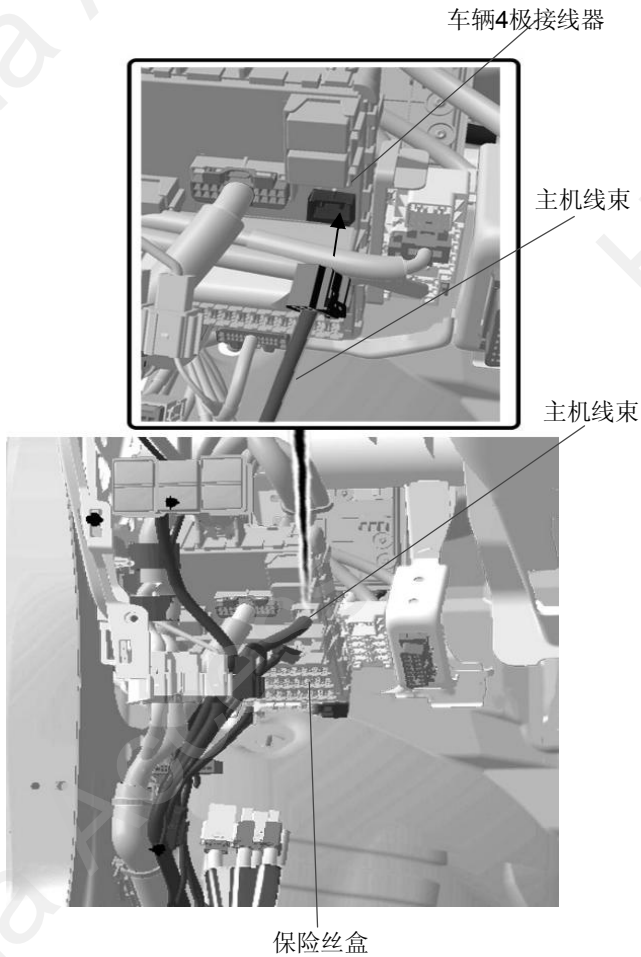

72. 铺放线束，连接车辆 6 极接线器。

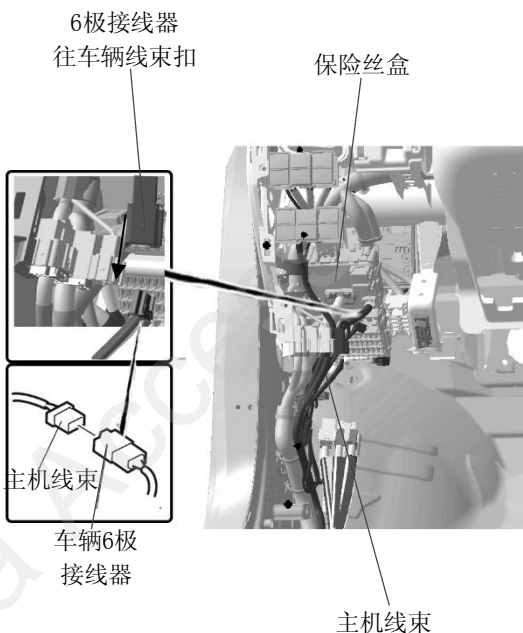

73. 铺放线束至驾驶座饰板功能按键的位置。

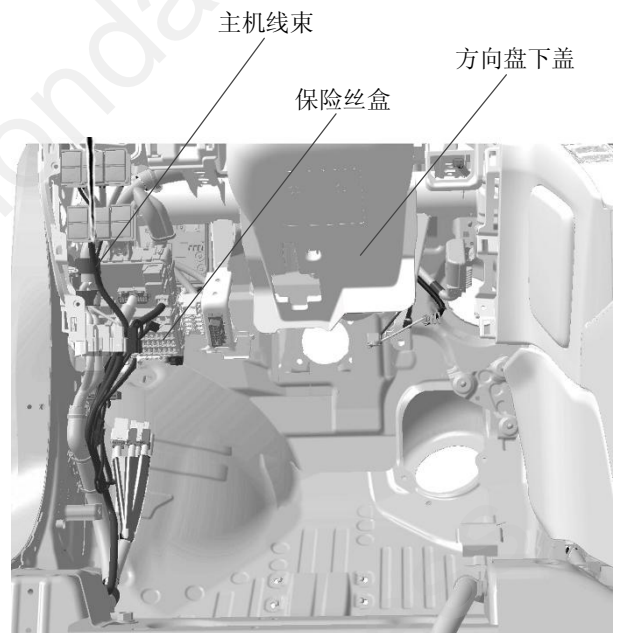

74. 连接车辆接线器。

- 混合动力车型 8 极或 4 极接线器
- 汽油车型 5 极接线器

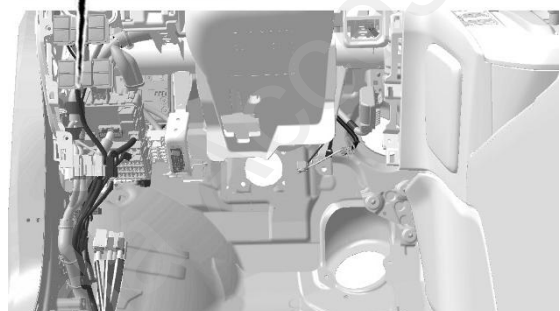
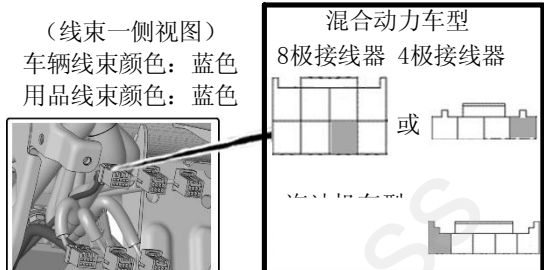

注意: 混合动力车型接线器有8极或者4极区别

75. 铺放线束，拔出车辆 40 极接线器。

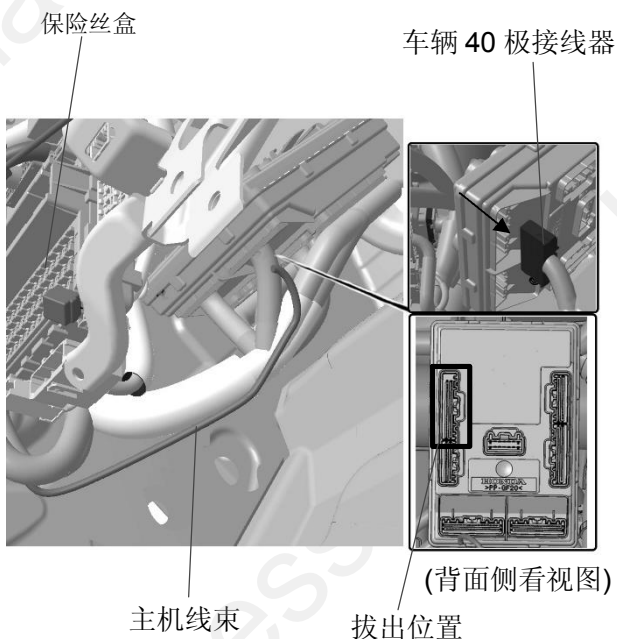

76. 主机线束连接车辆 40 极接线器。

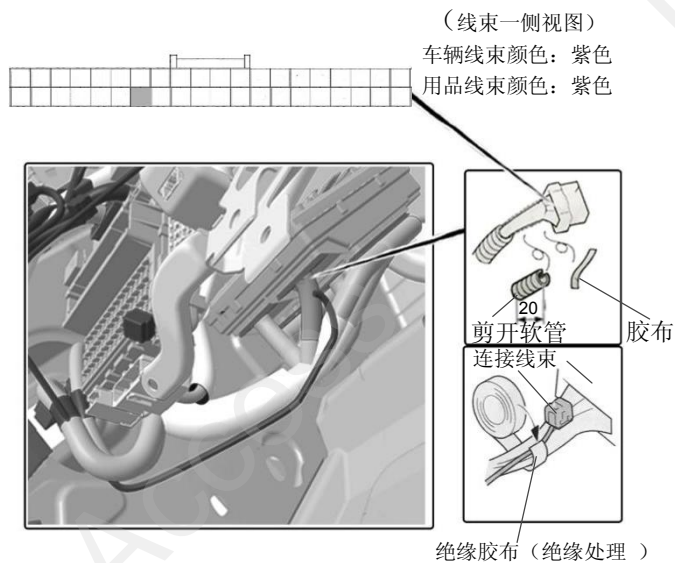

77. 铺放线束。

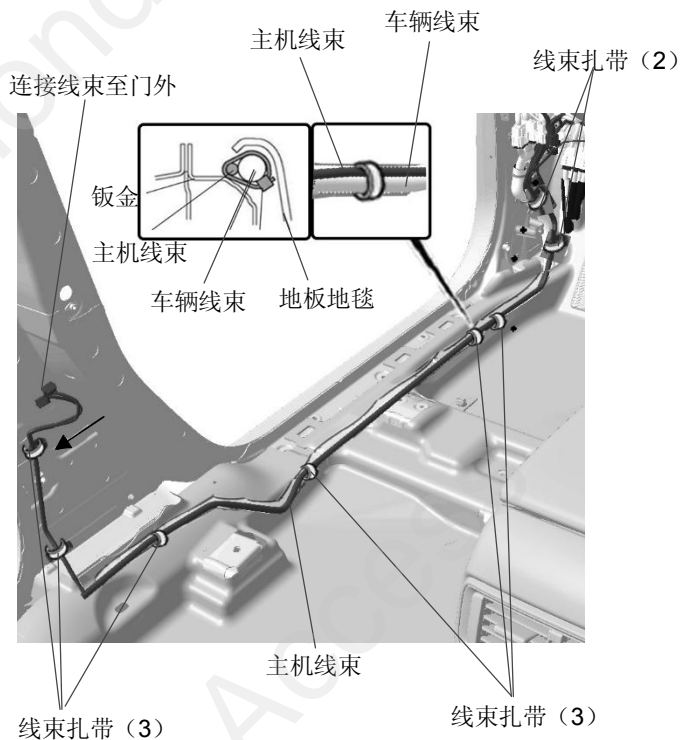

78. 铺放线束，拔出门外防水塞，连接车辆 25 极接线器。

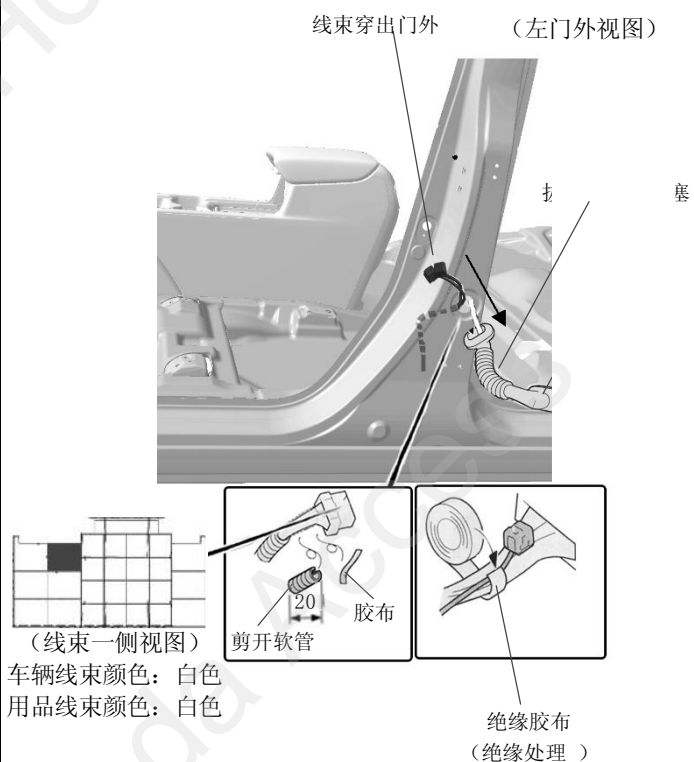

79. 铺放线束，连接地线端子。

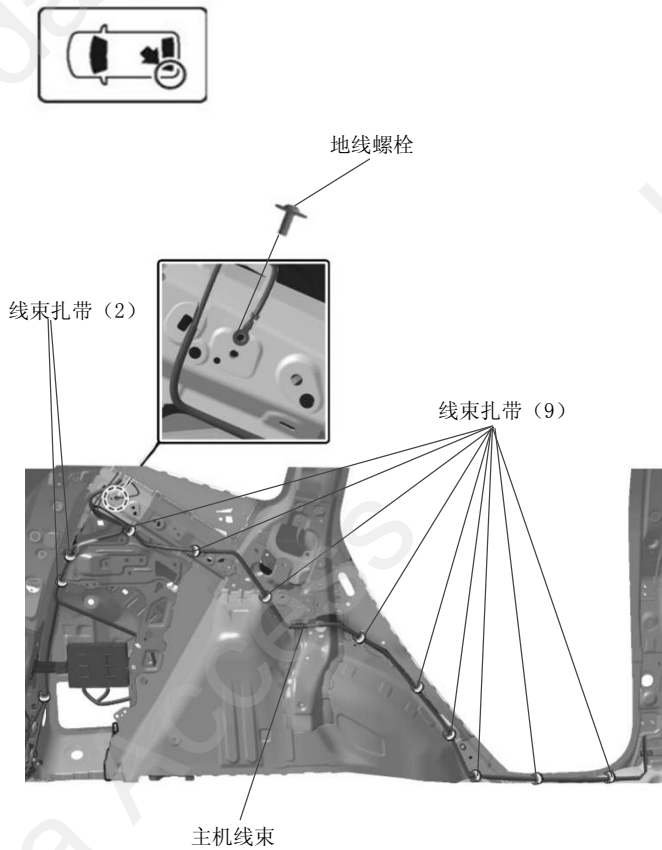

81. 连接 8 极接线器。

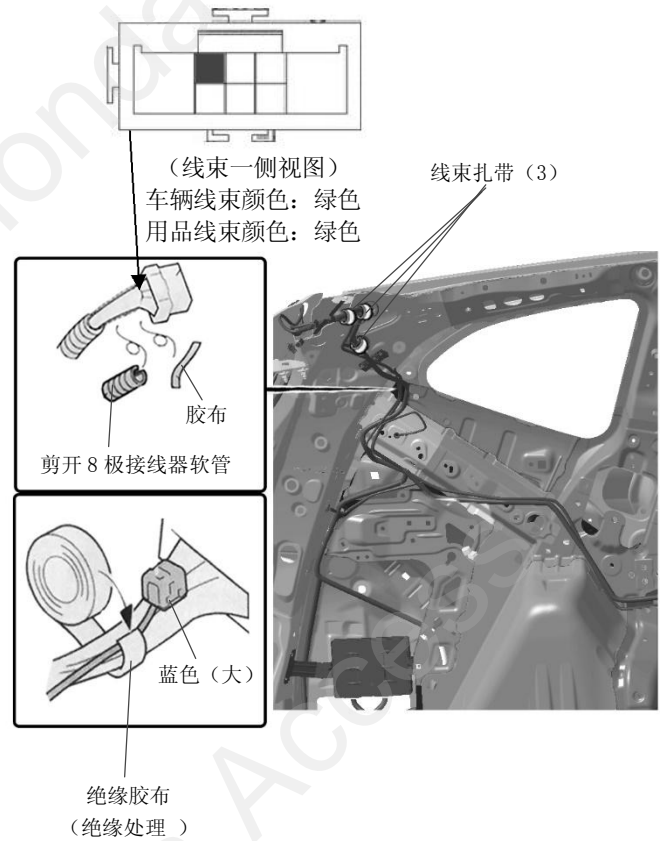

80. 连接主机，连接电动撑杆接线器。

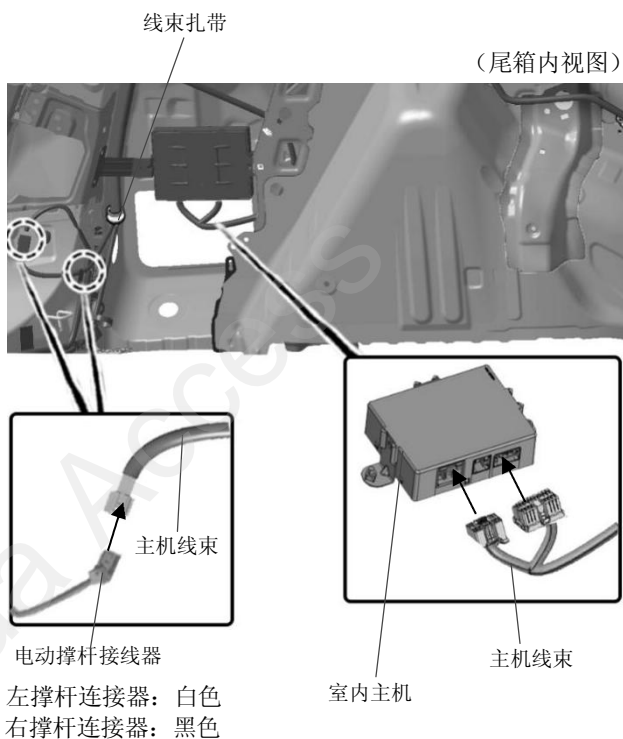

82. 拔出车辆索环。

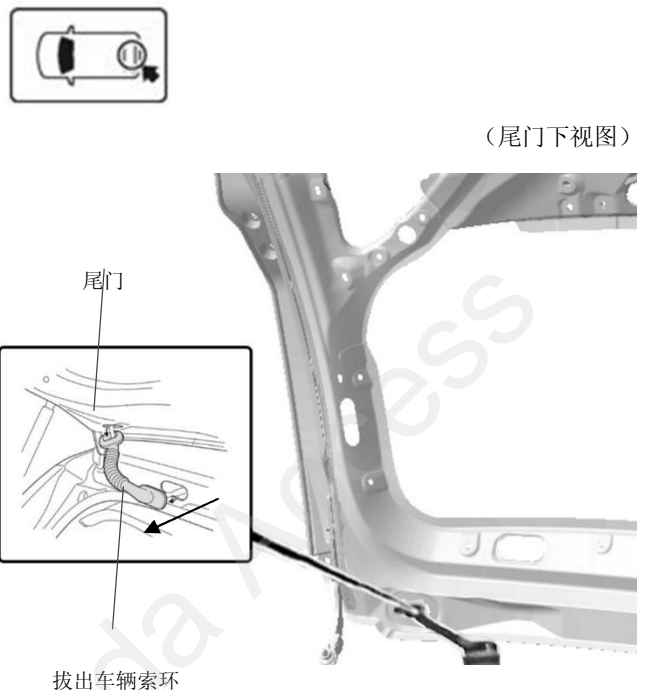

83. 铺放主机线束至门外,使用波纹管捆绑保护线束。

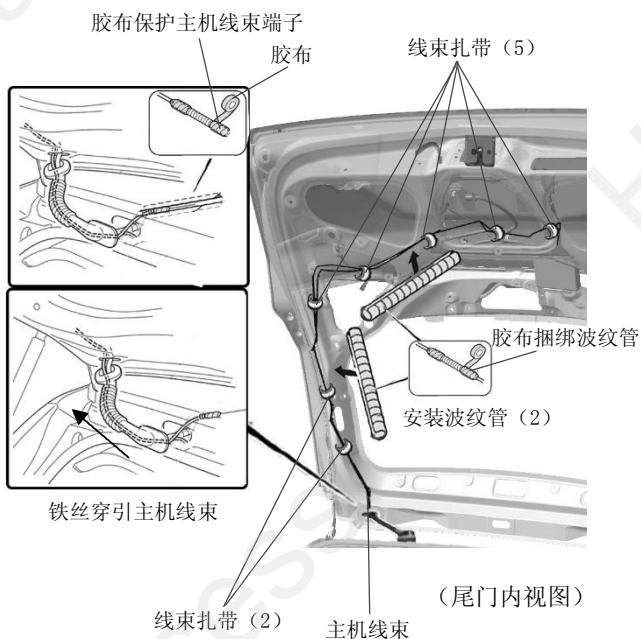

注意

- 胶布保护主机线束端子。
- 铁丝不要损伤车辆以及线束。

安装确认

85. 确认配线和安装没有异常。

建议

- 注意不要损伤车辆零件, 夹住线束。
- 必须牢固安装夹扣、爪扣等, 不能凸起。

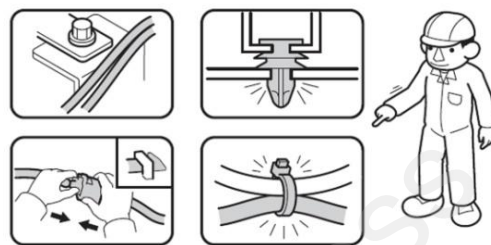

复原操作

84. 连接门内主机 24 极接线器, 连接 12 极接线器线束。

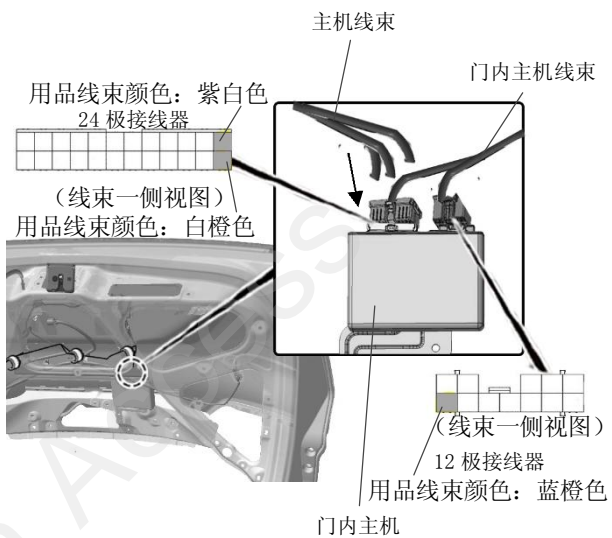

86. 安装新的门拉手。



87. 更换新的门拉手。

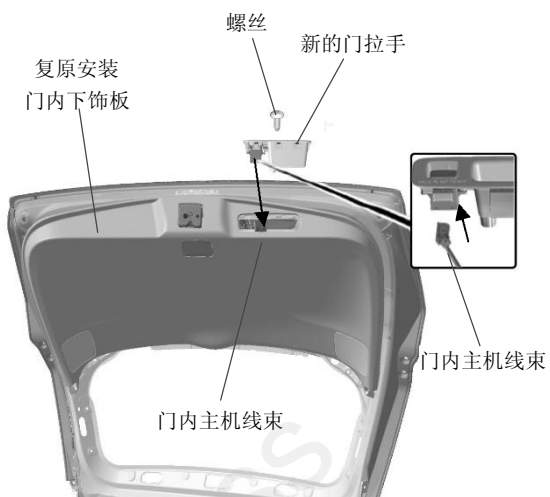

89. 更换新的室内开关按键。

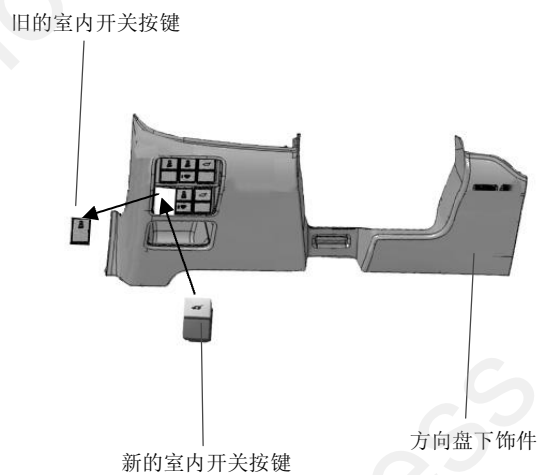

88. 扭紧门钉。

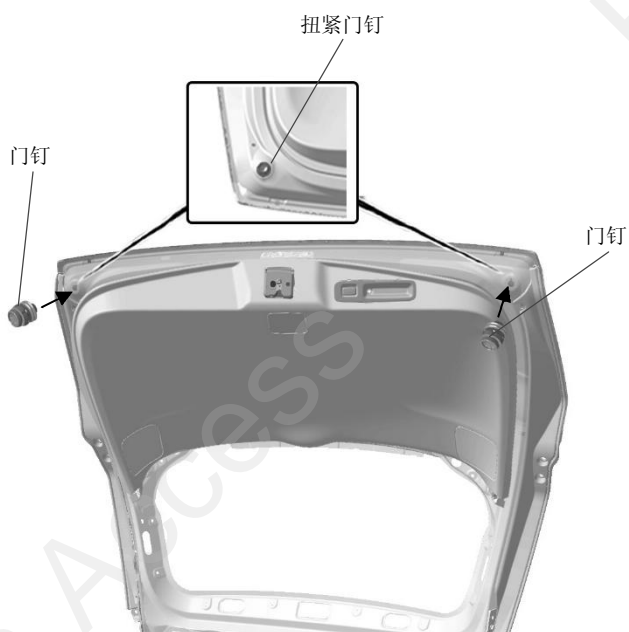

90. 连接室内开关按键接线器。

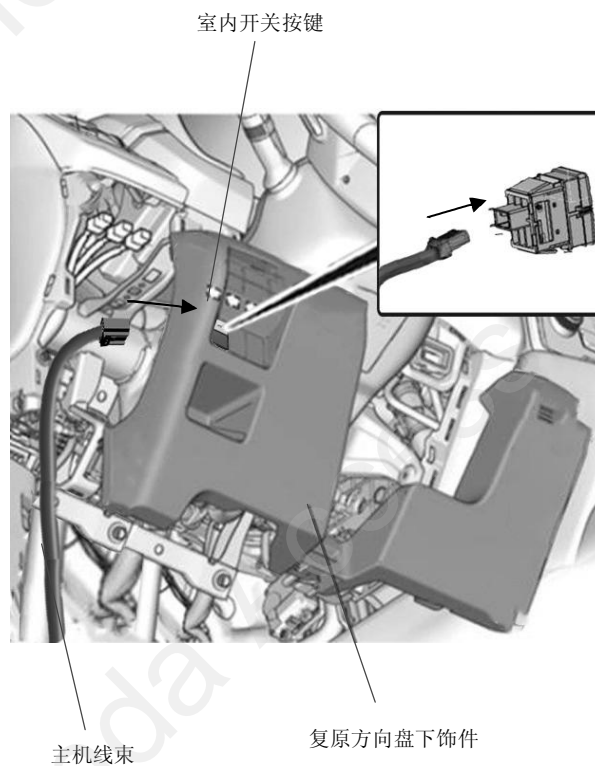

91. 切割保险杠，并复原保险杠。

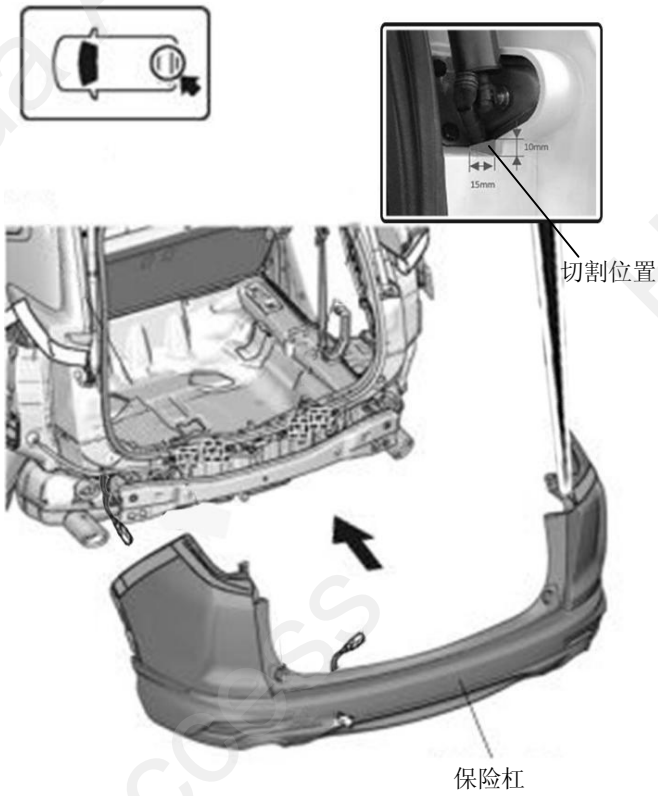

92. 把拆卸下来的车辆零件按原样装回。

建议

- 确认没有强行拉拽、夹塞、夹住线束。
- 确认夹扣和线束胶带安装牢固，没有遗漏。

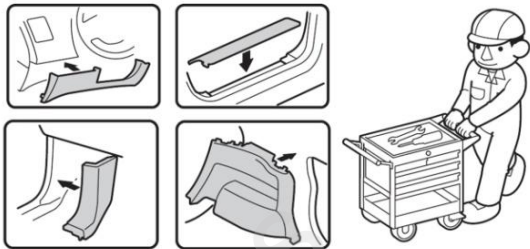

动作确认

93. 重新连接电池的负极端子。

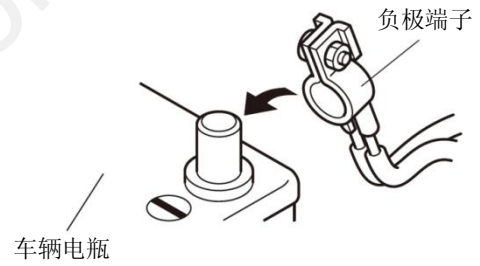

车辆检查

94. 确认电装产品及电子系统的运转正常。
95. 恢复各单元到安装前的设置状态。

